

Head Office

6, Ramo Gardens Buildings, Nasr City ,Cairo, Egypt
Tel: (+202) 230 54 352
Fax: (+202) 230 54 471

Central Sales Dept.

2, Asmaa Fahmy St., Heliopolis, Cairo, Egypt.
Tel: (+202) 241 75 822 / 229 01 056
Fax: (+202) 269 03 694

Show Rooms

Mohandseen

55, El Nakheel St., From El Batal Ahmed Abd El Aziz St.
Tel: (+202) 333 87 004 / 5
Fax: (+202) 333 87 006

Heliopolis

69, Nabil El Wakkad St., Ard El Golf
Tel.& Fax: (+202) 241 91 208 / 241 93 695

Alexandria

Next to 14 May Bridge, Saraya Style Bldgs, Smouha, Alexandria
Tel: (+203) 957 5907
Fax: (+203) 429 1766

Marsa Matrouh

13, Alexandria St., Alex Tower Bldg.
Tel: (+0246) 49 32 714
Fax:(+0246) 49 32 712

Assyut

El Adly St., Nasser Tower
Tel. & Fax: (+0288) 231 0252

Customer Service Tel.: (+202) 46 96 640

www.multigroup.com
e-mail: info@multigroup.com

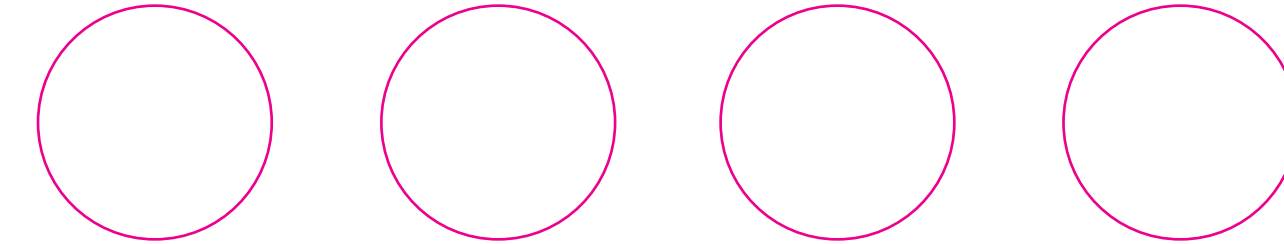

PROJECT INNOVATION VOLUME 2

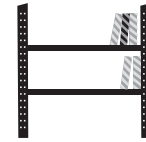

mohm

PROJECT INNOVATION VOLUME 2

index

projects: 01 dar el Kotub 05 gasco 07 barclays bank 09 cadbury 11 bibliotheca alexandrina

products: 39 office soft line 43 office m-plus line 45 office elegant line 49 office spider line 51 office partition line

71 chair 77 sofa 79 office counters 75 school education

17 the ministry of
investment

19 the federation
of egyptian
industries

21 the american
university in
cairo

23 credit agricole
bank

25 shooting
club

27 design
concept

57 office
basic line

59 office
dynamic
line

63 office
infinity pro

65 executive
novalinea

67 executive
italian

69 executive
ex elegant

projects

dar el kotub

gasco

barclays bank

cadbury

bibliotheca alexandrina

the ministry of investment

the federation of egyptian industries

the american university in cairo

shooting club

design concept

karim rashid

mohm at milan furniture fair





DAR El Kotub

The Egyptian national library [Dar El Kotub] is considered the biggest library in Egypt and one of the largest in the world. It houses several million volumes with wide range of topics that represent a huge archive for humanity at large with Arabic and Eastern manuscripts preserved since antiquity. Dar El Kotub was built after a decree from Khedive Ismail in 1870 with an initiative from the educational iconic reformer Ali Pasha Mubarak minister of education at that time. The oldest governmental library contains Arabic papyri from different sites in Egypt dating back to the seventh century, wide variety of manuscripts of the Qur'an with some in the early-undotted Kufic script and more than 57,000 of the most valuable manuscripts in the world. Being aware of the human treasury before it, mohm was keen when furnishing the place to add the most developed ultimate modern styles, which facilitate the access and use of such documents for the researchers from all over the world.







Mohm used the spider counter that adds through its curvy shape elegance and modernity to the place with its Clerk chair that guaranteed the comfort and mobility through the wheeled spider-like legs.

Mohm designed the furniture in Dar El Kotub to suit the nature of the place; The reading tables are equipped with soundproof separating metal walls that save privacy and help in preventing the external noise which adds to the reader's concentration. For more comfort, the Egyptian leading furniture company paid especial care to the chair's back to help the reader indulge in his book for hours of comfort through the high back chair from mohm's Clerk chair collection. Containing thousands of documents and books, mohm provided its metal shelves with illuminator neon lamps that facilitate reading the books titles yet produce indirect light, which does not have any harmful effect on the readers' eyes.

The conference room's chairs were made to guarantee comfort through the sponge material and the woody armchairs. Moreover, the foldable chairs were designed especially to consume space and make corridors for the guests through arrival or departure.





GASCO

The Egyptian national Gas Company (Gasco) is considered the biggest gas company in Egypt owning two branches in Cairo and Alexandria. Gasco is responsible for the transportation and distribution of gas from the production field to consumers all over Egypt. The company is also responsible for separating the natural gas's highly economical components in order to use them in different industries with upgrading the control, communication and data transmission systems to international standards.

A company with such a high profile requires furniture that is up to the standards, a mission that mohm easily achieved. From the classic collection, mohm chose the high back and Low back chairs both with wheels for the head office. A small rounded meeting room was a necessity and to give a since of intimacy through breaking the formal rigid look of a working office, mohm added the super comfortable Chesterfield sofas to the company's lounge. As for the offices, the L shaped elegant desk was employed brilliantly with the drawer unit to consume space and provide the most possible facilities.

The meeting room for Gasco represents the core of the company where important discussions take place resulting in crucial decisions. mohm paid special care to such area through providing an elegant massive seven-meter meeting table designed to meet the gas company's criteria and it's meeting room's dimensions. The table is also equipped with holes that provide a place for the wires of the thirty-one internally plugged-in mikes.





BARCLAYS Bank

Being an active member of the international Barclays conglomerate, Barclays Bank in Egypt capitalizes on the expertise and empowerment of the global enterprise to offer high value and unique products and services across the Egyptian market. The British bank founded in 1836, employs through its branches in Egypt more than 2,000 people and serves more than 100,000 customers across the country through a network of over 60 branches and 93 in-branch and off-site ATMs. With such a huge number of employees and investments in the country, Barclays trusted Mohm the innovative furniture company to handle the task of furnishing Cairo's branch while Barclays concentrate on the finance.

Being aware that a desk for any accountant is his sincere companion all through the nine to five working hours if it did not exceed, Mohm designs for the desks made work a daily pleasure with the low back chair from the classic collection (color optional) and the long curvy table. Mohm was able to overcome the challenging narrow space of the branch compared to the number of employees through the three L shaped elegant desk used as one desk however, to keep the privacy the desks are provided with soundproof separating glass walls (material optional).

As being highly aware of a bank's requirements and needs, Mohm paid especial care to Barclay's clients; the visitor armless chair was a great choice from the Florida collection. As for the employee, L shaped elegant desk with drawer unit is ideal to allow an easy access to any required files while dealing with client.





CADBURY

With a history dating back to the nineteenth century, the renowned British chocolate company established by John Cadbury (1801-1889) in Birmingham, break boundaries to launch its branch here in Egypt for a wide scale of admirers to the delicious taste of the chocolate trademark. Cadbury started its journey in Egypt since 1991 with its first three products Cadbury Dairy Milk (CDM), Cadbury Dairy Milk Crisp and Cadbury Dairy Milk Hazelnut. No sooner, the company expanded it's business to target the middle class through acquiring BimBim the leading local confectionery business in Egypt established in 1977, then finally the unstoppable ambitious company acquired Adams (Incogum) where Cadbury Egypt Group Adams, Incogum started.

Such a success story requires cutting-edge elegance yet simple furniture to suit the business nature. The manager desk with a manager chair and two high back chairs from Florida collection epitomizes simplicity yet glamour along with the mirror surface locker. The small rounded meeting room along with five visitor chairs from the Florida chair collection was such an ideal choice to occupy the narrow space of the room. The workstation attached with a printer holder was provided with 80 mm separating partitions to give privacy and prevent noise in addition to an anti-scratch layer added to the desks. Being the face of the office, mohm was keen on designing an elegant and comforting reception through the Sienna 1-seat, and 2-seat couch.

The meeting room for lectures is far from ordinary; it can be used as either a meeting room by attaching the aluminum legged tables to one another or a working station with separate tables and low back chairs from mohm's classic collection.





BIBLIOTHECA

Alexandrina

The reconstruction of Bibliotheca Alexandrina was a national desire to revive the ancient glory of the old library lost in antiquity, which was built by orders from Ptolemy II of Egypt in the beginning of the third century BC. The library included about 700,000 books from all over the world with original handwriting. However, as nothing stops the stream of culture like war, the library was destroyed in the fighting between Ceasar and Ptolemy XII.





BIBLIOTHECA

Alexandrina

The revive of Bibliotheca Alexandrina (Library of Alexandria in Latin) goes back to 1989 when the Egyptian government announced the competition for a new design to the library to be constructed on the same ground of the ancient bibliotheca. The library's construction process took twenty years with the help of the UNESCO and a cost of 200 million dollars to be one of the biggest libraries and cultural centers in the world. Welcoming more than 800,000 visitors a year, the library includes a main reading room, conference center; specialized libraries for the blind, for young people and for children; three museums; four art galleries; a planetarium; and a manuscript restoration laboratory.

Such enormous project required furniture with a high quality and a great eye on details to match the dazzling sophisticated standards of the library which mohm handled through furnishing 90% of the whole library with customized pieces.





BIBLIOTHECA

Alexandrina

A library with a main reading room covering 70,000 m² on eleven cascading levels needed an exceptional form of design by mohm, a mission that the innovative furniture company accomplished easily. Setting the visitors comfort as its first priority, mohm designed chairs especially for the library to suit its enormous hall with a relaxing back seat. With a capacity of eight million books, the shelves design allows it to afford the marvelous treasures within which mohm made sure to emphasize through the neon lamps attached to the shelves for facilitating the browsing process. Being a cultural minaret for the world, mohm could not have missed the illumination factor in the library; the aluminum lamps attached to the reading tables that were designed specially in a zigzag shape to allow the reader to benefit as much as possible from the light.



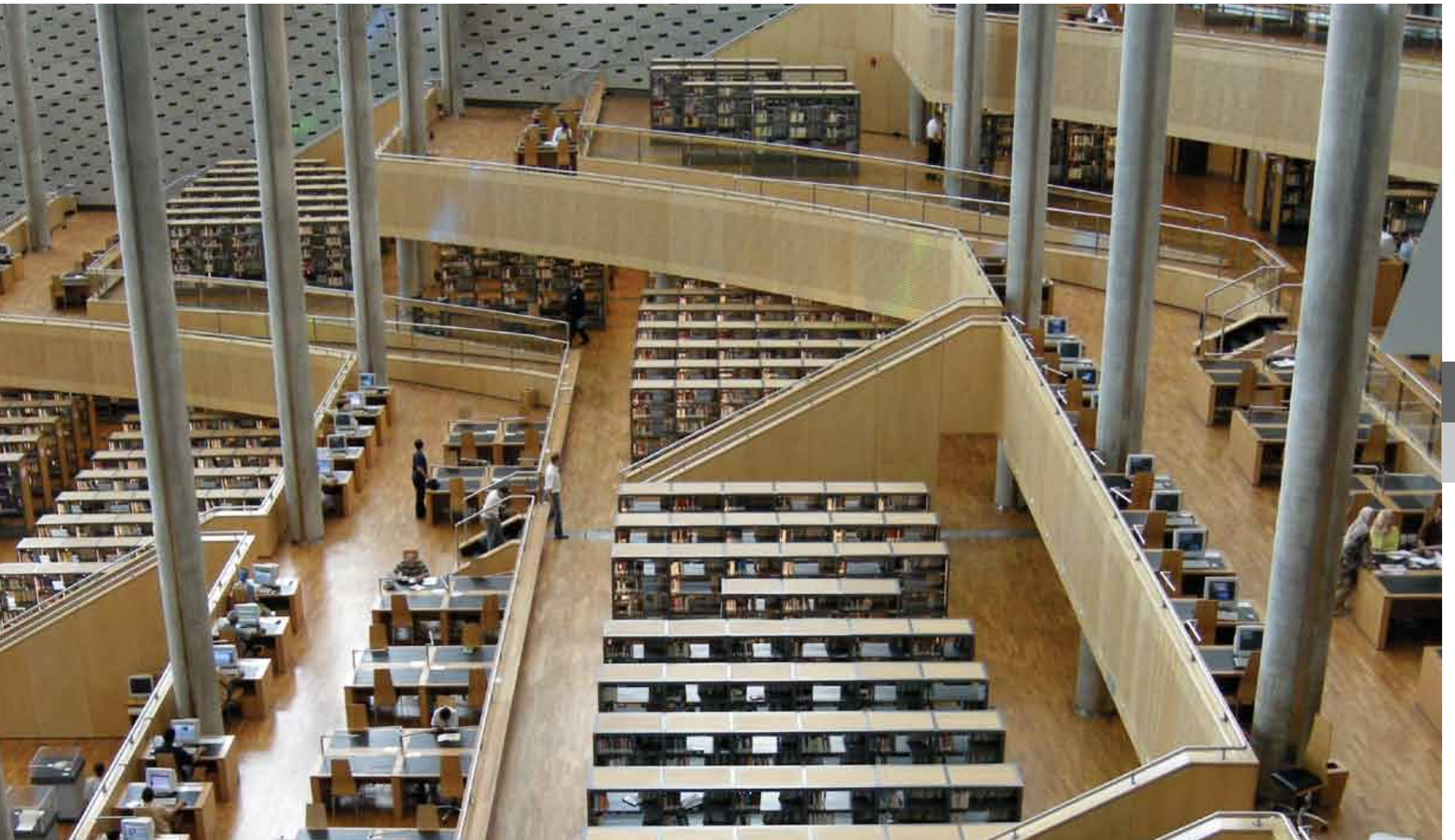

THE MINISTRY OF Investment

The Ministry of Investment is the principle governmental authority concerned with regulating and facilitating investment, and stands ready to assist investors worldwide. It represents Egypt's sole "One Stop Shop" for investment, which aims at easing the way for investors worldwide to take advantage of the opportunities in Egypt's promising emerging market.

A company with such a vivid youthful spirit, which attempts to break the bureaucracy that complicates investments in Egypt, required practical yet elegant furniture. mohm put the Ministry of Investment profile into practice through it's 8cm thickness used as workstations with drawer unit from the M-Plus collection. Despite the highly practical and space consuming advantage of the workstations, privacy might be at risk; an obstacle that the innovative furniture company easily overcame through the soundproof separating wooden walls (material optional). Moreover, to keep the workstation even more practical and being aware of technology's major role in investment, mohm provided the partitions with electricity and telephone sockets. The Egyptian leading furniture company added to the workstation a unique sense of elegance through the glass separating walls where neon lamps were added to the glassy wall to give glamorous look when switched on as well as illumination.





THE FEDERATION of Egyptian Industries

The FEI was first established in 1922 and today it overlooks the operations and tackles the barriers facing the entire Industrial Sector. This is achieved through 16 dynamic, highly active Chambers and 19 Decision Support Committees that are constantly developing programs and services to facilitate and support the various industries within Egypt. mohm matched the FEI requirements through its cabinets and practical workstations provided with fabric designed partitions that can easily be used for sticking work papers and reminders as well as electronic and telephone sockets for computer uses and internet. Since mohm's notion of being practical never conflicts with elegance and ultimate style, the Egyptian leading company matched the partitions color with the Sphere Low Back chair to appeal to the employees.

Since first impressions last, mohm paid exceptional care when it comes to the FEI's reception office. The Spider Counter was an ideal choice with its curvy elegant look, which is one of mohm's latest collections.





THE AMERICAN University in Cairo

The AUC was founded in 1919 by Americans devoted to education and community service in the Middle East. Today, the University is the region's premier English-language university, an essential contributor to the social, political and cultural life of the Arab world. It also serves as a crossroads for the world's cultures: a vital, vibrant forum for reasoned argument, spirited debate and global understanding. For the ultimate comfort of the leading university's students, mohm provided newly developed Lockers for AUC, which kept the student's privacy and protected their items through its unbreakable locks. Moreover, the five-level full open cabinet provided unlimited capacity to the users.

As freedom of academic expression is fundamental to AUC in particular apart from any other university in Cairo, mohm paid special care when designing the lectures rooms where all the debates and progressive discussions are carried out. Through the Premium Metal Furniture line specially developed for AUC, the folded wheeled tables and chairs were the ideal solution, to maintain the youthful spirit of the place where the tables can be used as a huge meeting table or separate desks.





CREDIT AGRICOLE Bank

Credit Agricole is active in all segments of banking and finance, It is active in over 70 countries Egypt is one of them, with more than 160,000 employees, with such a huge number of employees and investments , CREDIT AGRICOLE trusted MOHM the innovative furniture company to handle the task of furnishing its branches . As being a highly aware of bank's requirements and needs, mohm paid exceptional care for credit agricole, by creating a new style counter made of metal sheets and wood with colors green & gray (color optional) to fit credit agricole environment and needs , as it ranked by retail banking revenues.

Being aware that a desk for any employee is his sincere companion all through the nine to five working hours if it did not exceed, so mohm designs for desks made work a daily pleasure, also desk is provided with a drawer unit ideal to allow an easy access to any required files while dealing with client, it is made of the same material of the desk (color optional), As for the employee need to save the important work files, mohm designed cabinets with a variety in dimension to fit all needs, it is made also of the same material and color.





SHOOTING Club

One of the most famous clubs in Egypt, also known as Nadi al-Seid, this vast complex offers a wide range of sports and recreational facilities. You will not be surprised to learn that it specializes in clay pigeon shooting but, if this is not your cup of tea, there are plenty of other sports you can indulge in. Soccer, swimming, martial arts, pool, ping pong, squash and tennis are just a few of the activities on offer. The fully equipped gym also offers an impressive range of facilities.

Also shooting club trusted Mohm the innovative furniture company to handle the task of furnishing its dressing rooms, so Mohm provided newly developed metal lockers painted in new colors (colors optional) used to protect users' private items from loss. Also Mohm paid exceptional care for Shooting Club by creating comfortable wooden benches, to fit the overall atmosphere of Shooting Club & to provide relaxation for its users.





DESIGN Concept

Since 1991 when the furniture company started, mohm took an oath to be the innovative contemporary Egyptian furniture company that matches universal standards. Such a progression was not an easy task; with the hard work of 1200 workers and high-tech machines along with 6 factories, mohm was able to engrave its name in the furniture business worldwide. To keep its leadership and important role in flourishing Egyptian furniture industry, mohm is always keen on keeping up with the latest designs and styles through its annual exhibition which reflects the company's latest collections.



mohm
FURNITURE INNOVATION

Creativity can solve almost any problem.
The creative act, the defeat of habit by
originality, overcomes everything.

“ Principles for the
Development of a
Complete Mind:
Study the science of art.
Study the art of science.
Develop your senses
especially learn how
to think. Realize that
everything connects to
everything else.”

mohm
FURNITURE INNOVATION

DESIGN Concept

The new Novalinea Desk collection from mohm is a modern yet relaxing collection. The Elegant in Style collection from mohm sums up the company's philosophy towards design, the high back white chair along with the decorated partition gives a classy look that appeal to the eye. A must-have piece of furniture in any office's lounge is the super comforting Hamburg sofa with two seats that is available in black and white.





DESIGN Concept

With an impressive list of foreign clients that include French, Italian, British and German companies, mohm presents through its new collection variety of meeting tables that suit any taste and meet wide range of requirements. The Meeting Table from Novalinea collection affords more than eight Sphere low back chairs in addition to the simple yet elegant open cabinet from the Novalinea collection.





KARIM Rashid

Karim Rashid is one of the most prolific designers of his generation. Over 3000 designs in production, over 300 awards and working in over 35 countries attest to Karim's legend of design. The Egyptian born artist's award-winning designs include democratic objects such as the ubiquitous Garbo waste can and Oh Chair for Umbra, interiors such as the Morimoto restaurant, Philadelphia and Semiramis hotel, Athens and exhibitions for Deutsche Bank and Audi. The New York based designer has collaborated with clients to create democratic designs (Rashid believes that high-quality design should be accessible to the masses) for Method and Dirt Devil, furniture for Artemide and Magis, brand identity for Citibank and Hyundai, high tech products for LaCie and Samsung, and luxury goods for Veuve Clicquot and Swarovski. Karim's work is featured in 20 permanent collections and he exhibits art in galleries worldwide.

As both mohm and Karim Rashid share the same vision of an innovative sense of style and modernity, Karim Rashid cooperated with mohm to release the most modern functional and holistic furniture line.

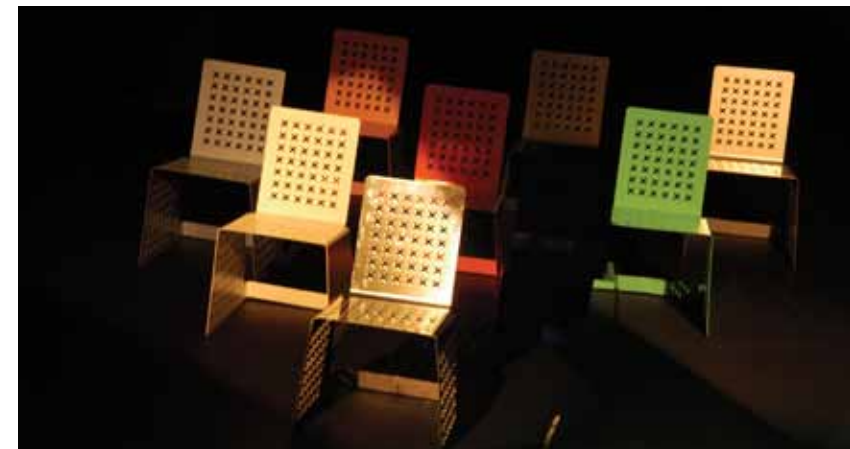



mohm at Milan Furniture Fair

The Salone Internazionale del Mobile di Milano was launched for the first time in 1961 by a small coalition of furniture manufacturers, from within the Federlegno-Arredo trade association, with the aim of promoting the exportation of Italian furniture, and which soon became the most prestigious international event in the world of furniture design and production. As one of the leading furniture companies in the Middle East, mohm is always keen on sharing in the fair with the latest trendy designs. Sun Stool and Table by Hary & Camila is a multifunction stackable object, low chair, side tables and for stocking objects under the removable shell, inspired by the movement of the sun and its relation between the cosmos and pyramids, which is endless. Besque Bench is a bench full of character, excitement and mystery, by trying to follow the way the sunlight plays with the object and its shadow, revealing new aspects from every angle. The Taktouka Table designed by Karim Mekhtigian was an interpretation of the popular local icon of Egyptian coffee shop table for mohm. In the design inspired by this local icon, the Taktouka Table is using a basic material like metal in a design featuring intricate details. Profile Table by Shinichiro Ogata was designed with overlapping silhouettes that symbolize religion and culture from ancient to present ages that are used under a layer concept. The table's legs faithfully express the rich accumulation of history through the multiple layers it possesses.

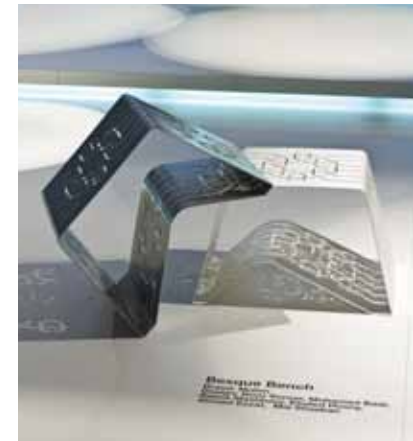



products

office soft line
office m-plus line
office elegant line
office spider line
office partition line
office basic line
office dynamic line
office infinity pro
executive novalinea
executive italian
executive fly system
chair
sofa
office counter
school (education)

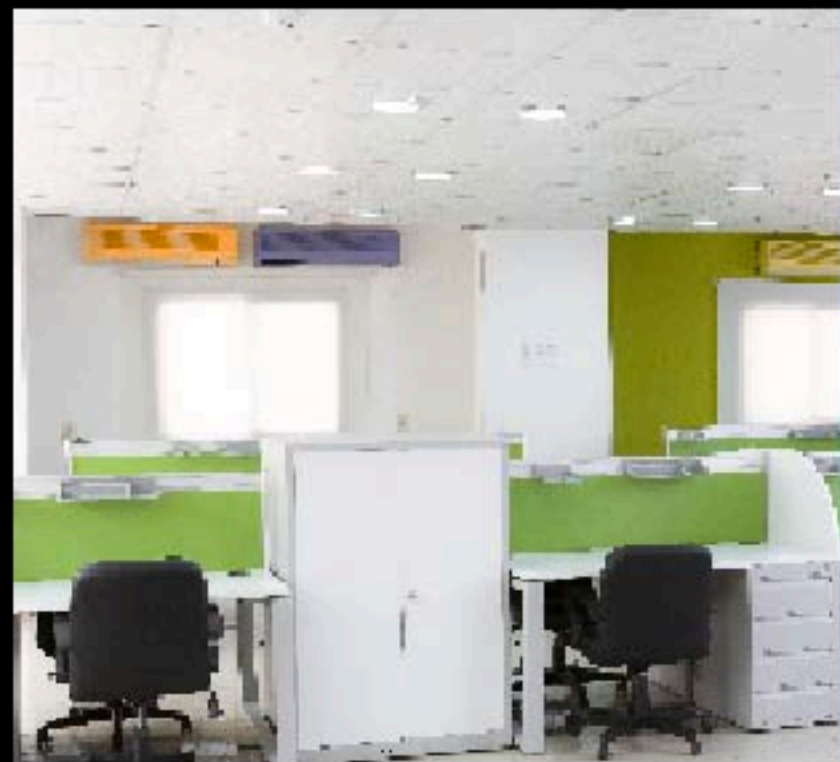

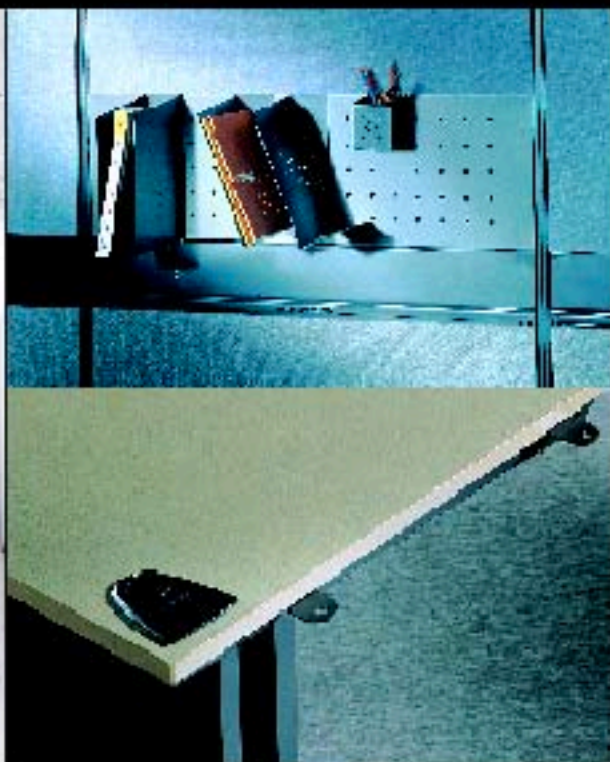

OFFICE

Soft Line

The Office Soft Line from mohm depicts the company's vision in breaking the norms of a typical traditional office with the simple yet modern designs of the line. The line's series contains multiple pieces that meet the client's requirements regardless of his business nature or office's space. The L-return Desk provides storage capacity for its desk and cabinet combination where a drawer unit can be added. The printer desk with its modular style is capable of dealing with any kind of printers through its flexible design. As for the Storage Cabinet in the soft line collection, it is one of the line's most distinguishing pieces where the collection provides wide range of drawers and cabinets with customized sizes and functionality.



Standard Desks

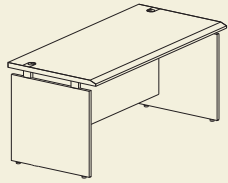

MKD 120 (1200x800x725)
140 (1400x800x725)
160 (1600x800x725)

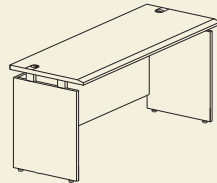

MKSD100 (1000x600x725)
120 (1200x600x725)
140 (1400x600x725)
160 (1600x600x725)

Manager Desk

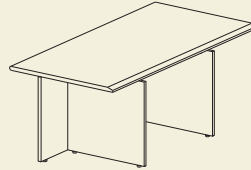

MKD 180
(1800x900x740)

Side Desk

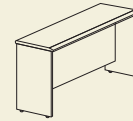

MKS 100
(1000x440x690)

Computer & Printer Desks

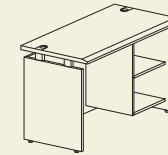

MKCD 120
(1200x600x725)

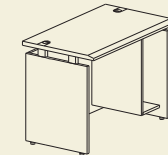

MKCD 100
(1000x600x725)

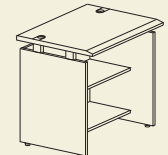

MKCD 080
(800x600x725)

Assembled Manager Desk

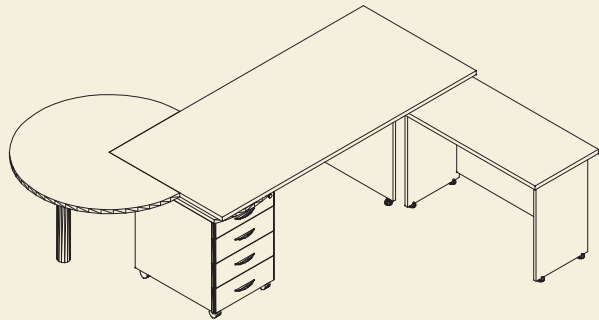

Desk 1 MKD 180
Side Desk 1 MKS 100
Extension 1 MKCN 002
Darwer 1 MKDW 303

Tea Tables

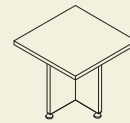

MKT 550
(500x500x430)



MKT 550R
(500x500x430)

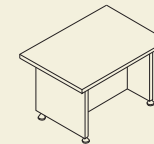

MKT 570
(700x500x430)

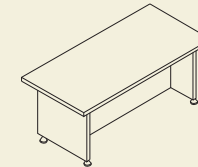

MKT 512
(1200x500x430)

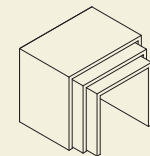

ST/S3
Set of three tables
(570x390x500)
(500x390x460)
(430x390x425)

Drawers

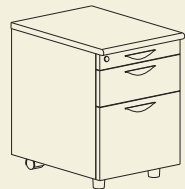

MKDW 302 (430x600x600)



MKDW 303 (430x600x600)

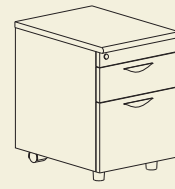

MKDW 202 (430x600x600)
102 (430x605x606)



MKDW 203 (435x605x606)
103 (435x605x606)



MKDW 403 (435x450x606)

Hanging File Drawers

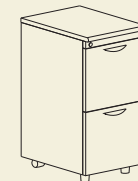

MKF 302 (500x600x845)



MKF 303 (500x600x1195)



MKF 304 (500x604x1485)

Connector Units

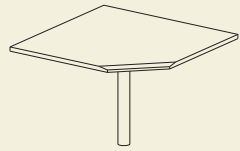

MKCN 112
(1100x1100x740)

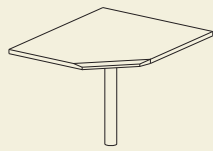

MKCN 110R
(1100x900x740)

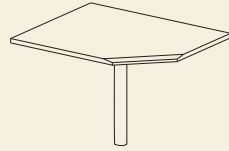

MKCN 110L
(900x1100x740)

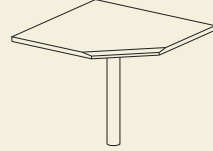

MKCN 090
(900x900x740)

Extension Units

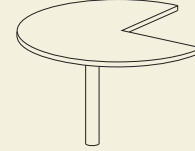

MKCN 002
(1200xH700)

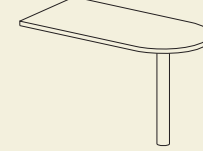

MKCN 612
(1200x600x740)

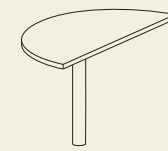

MKCN 012
(1200x600x740)

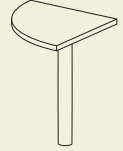

MKCN 006
(600x600x740)

Cabinets

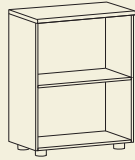

MKC 280
(800x400x800)

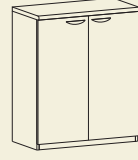

MKC 280BD
(800x400x800)

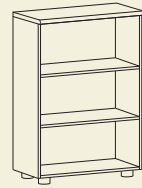

MKC 380
(800x400x1200)

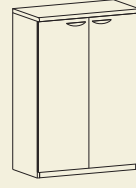

MKC 380UD
(800x400x1200)

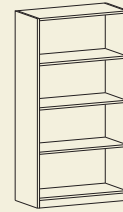

MKC 480
(800x400x1600)

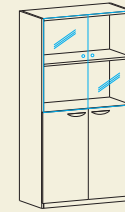

MKC 480BD/GD
(800x400x1600)

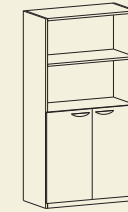

MKC 480BD
(800x400x1600)



MKC 480BD/UD
(800x400x1600)

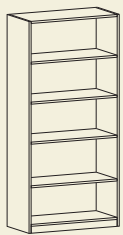

MKC 580
(800x400x1990)

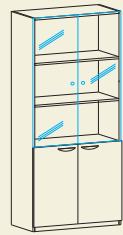

MKC 580 BD/GD
(800x400x1990)

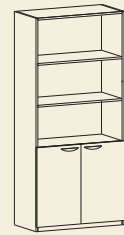

MKC 580 BD
(800x400x1990)



MKC 580 BD/UD
(800x400x1990)

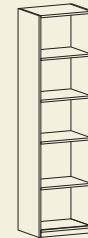

MKC 550
(500x400x1990)

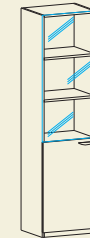

MKC 550 GD
(500x400x1990)

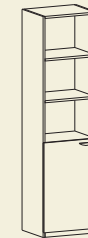

MKC 550 BD
(500x400x1990)



MKC 550 BD/UD
(500x400x1990)

Conference



MKCF100 (1000xH740)
120 (1200xH740)

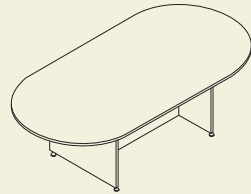

MKCFC 180 (1800x900x740)
220 (2200x1200x740)
240 (2400x1200x740)

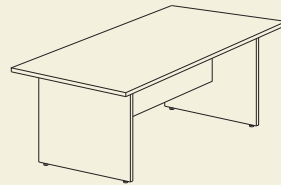

MKCF180 (1800x900x740)
220 (2200x1200x740)
240 (2400x1200x740)

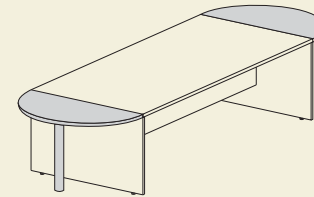

MKCN 012 (1200x600x740)

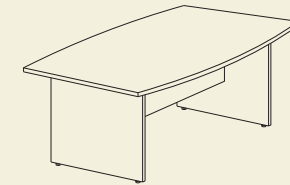

MKCF180/O (1800x900x740)
220/O (2200x1200x740)
240/O (2400x1200x740)

Conference Unit

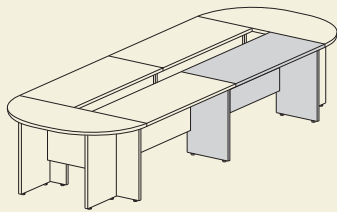

MKCF080 (800x600x740)
120 (1200x600x740)
140 (1400x600x740)
160 (1600x600x740)

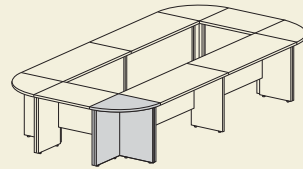

MKCF060 (600x600x740)

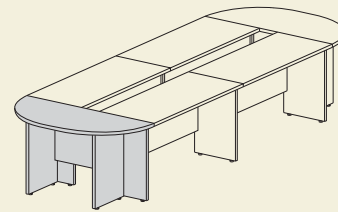

MKCFE 140 (1400x600x740)
160 (1600x600x740)

OFFICE

M-plus Line



mohm's M-Plus collection is distinguished with the brilliant mix of metal and wood to release an elegant piece of art in a client's office. Paying special care to the minute details of the design to occupy the smallest space possible with the biggest capacity, the CPU Holder is a great example of such concept along with the round-shaped Printer Holder provided with wheeled legs to facilitate mobility. The Drawer Unit is divided into drawers and pen tray for small sensitive items. The M-plus desk is a plus-size pleasure with its elegant decorated metal front available in various sizes as well as the metal cabinet that can easily embrace all the office's files and archive through its super-sized space.

Work Stations

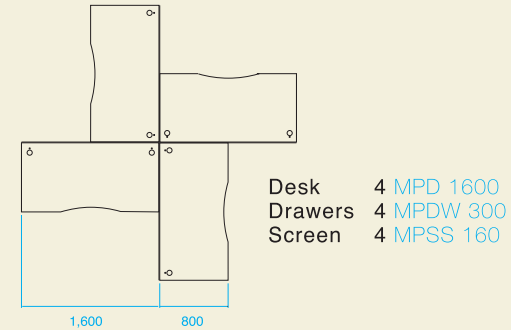
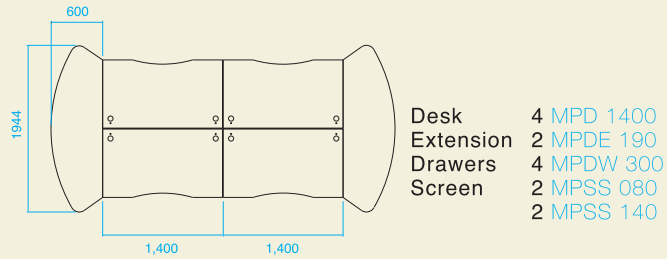
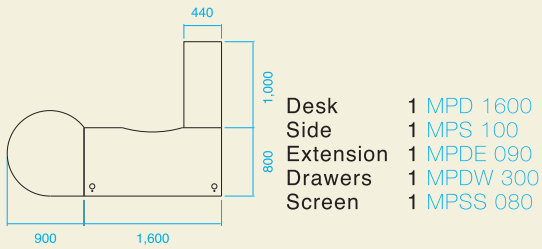

Extensions

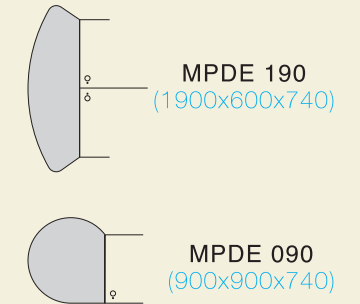

Desks

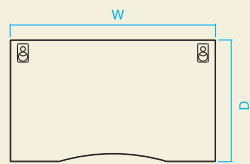

MPD 100 (1000x800x740)
120 (1200x800x740)
140 (1400x800x740)
160 (1600x800x740)
180 (1800x800x740)

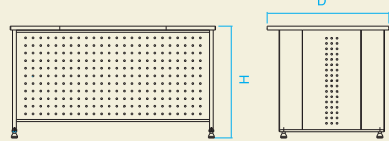

MPSD080 (800x600x740)
100 (1000x600x740)
120 (1200x600x740)
140 (1400x600x740)
160 (1600x600x740)

Side Desk

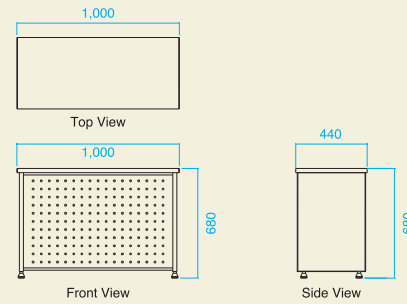

MPS 100
(1000x440x680)

Printer Holder

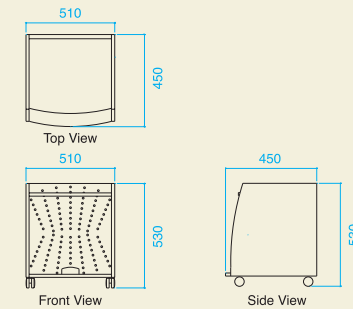

MPC 450
(473x457x608)

CPU Holder

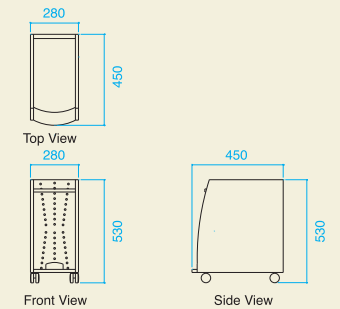

MPC 280
(280x457x608)

Cabinets

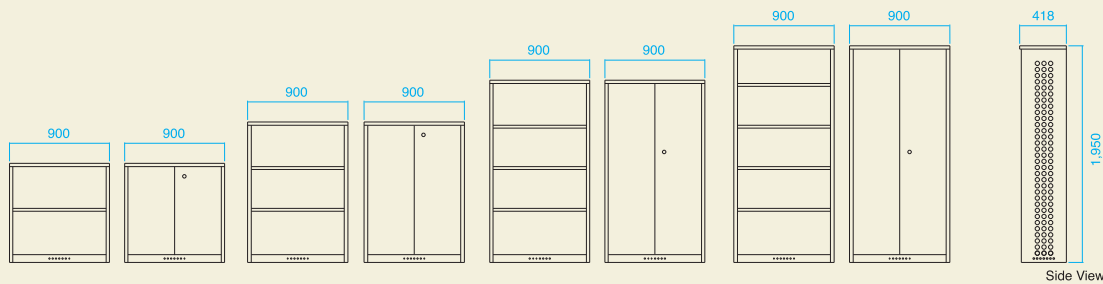

MPCD090
(900x417x900)

MPCD120
(900x417x1275)

MPCD160
(900x417x1650)

MPCD190
(900x417x1950)

MPCD180
(900x417x1820)

Drawers

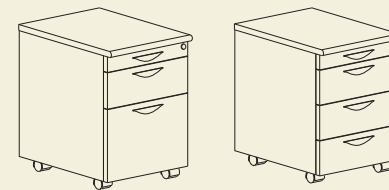

MPDW 200
(432x610x610)

MPDW 300
(432x610x610)

Screens



MPS 08 (G/GS/W) (800x520)
MPS 10 (G/GS/W) (1000x520)
MPS 12 (G/GS/W) (1200x520)
MPS 14 (G/GS/W) (1400x520)
MPS 16 (G/GS/W) (1600x520)

MPSC 08 (G/GS/W) (800x520)
MPSC 10 (G/GS/W) (1000x520)
MPSC 12 (G/GS/W) (1200x520)
MPSC 14 (G/GS/W) (1400x520)
MPSC 16 (G/GS/W) (1600x520)

G= Glass (thk=10mm)
GS= Glass sanded (thk=10mm)
W= Wood (thk=18mm)

OFFICE

Elegant Line

mohm is keen through it's various range of collections to satisfy and match the market requirements through manipulating different materials. In the Elegant collection, mohm has ecexcelled in creating a complete cabling solutions. Moreover, it perfectly matches conventional private offices to achieve a cohesive appearance. The desk's durable metal legs can facilitate station design. As for the side desks, it can match easily the taste of clients who seek simplicity and practical pieces. The desk's laminate surface is quite durable to scratching & acids as well as heat.





Standard Desks

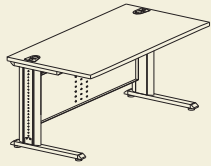

ED 080 (800x800x745)
 100 (1000x800x745)
 120 (1200x800x745)
 140 (1400x800x745)
 160 (1600x800x745)
 180 (1800x800x745)

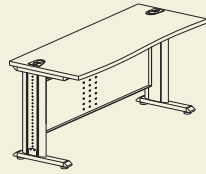

ESD 080 (800x600x745)
 100 (1000x600x745)
 120 (1200x600x745)
 140 (1400x600x745)
 160 (1600x600x745)
 180 (1800x600x745)

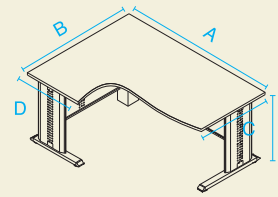

ELD 1412 (1400x1200x600x600x700)
 ELD 1612 (1600x1200x600x600x700)

Side Desk

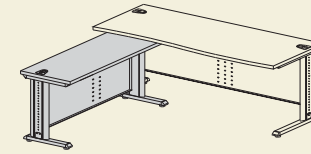

ES 100 (1000x500x685)

Computer Desk

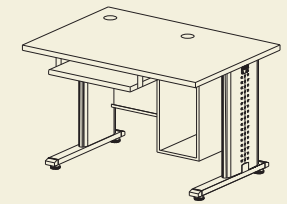

ECT15/60
 (1050x600x770)

Hanging Files Drawers

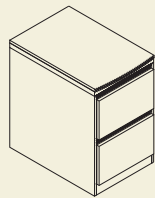

C200
 (460x660x726)

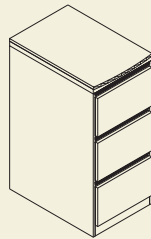

C300
 (460x660x1032)



C400
 (460x660x1338)

Round Table



MECF 100 (1000xH740)
 120 (1200xH740)

Screens

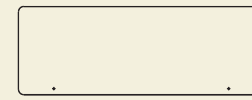

ELS 08 (G/GS/W) (800x520)
 ELS 10 (G/GS/W) (1000x520)
 ELS 12 (G/GS/W) (1200x520)
 ELS 14 (G/GS/W) (1400x520)
 ELS 16 (G/GS/W) (1600x520)

G= Glass (thk=10mm)
 GS= Glass sanded (thk=10mm)
 W= Wood (thk=18mm)

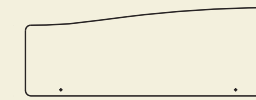

ELSC 08 (G/GS/W) (800x520)
 ELSC 10 (G/GS/W) (1000x520)
 ELSC 12 (G/GS/W) (1200x520)
 ELSC 14 (G/GS/W) (1400x520)
 ELSC 16 (G/GS/W) (1600x520)

Work Station

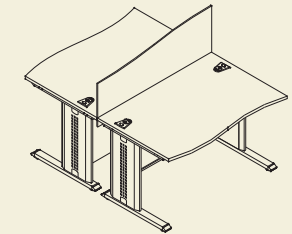

Desk 2 ESD 120
 Screen 1 ELSC 12 GS

Conference Table

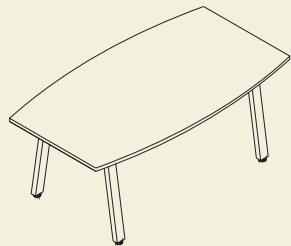

ECF 180 (1800x1100x720)
 210 (2100x1100x720)
 240 (2400x1100x720)

Conference Units

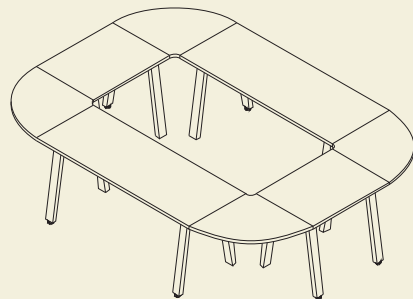

ECF 16
 (1600x600x730)



ECF 14
 (1400x600x730)



ECF 12
 (1200x600x730)



ECF 08
 (800x600x730)



ECFL 01
 End Leg (H=730)



ECF 06
 Connector
 (600x600)

Endless

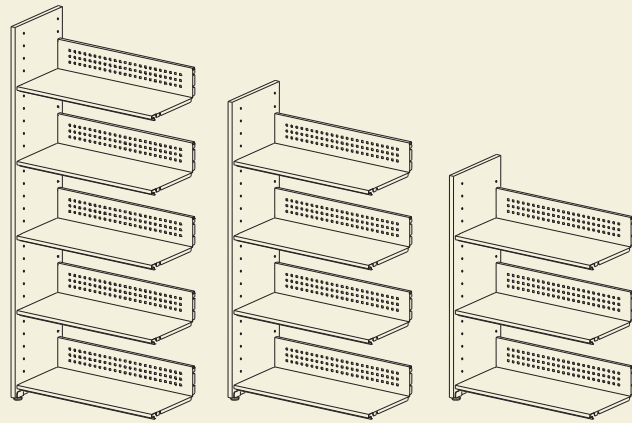

EEC 819
(830x400x1915)

EEC 816
(830x400x1655)

EEC 812
(830x400x1207)

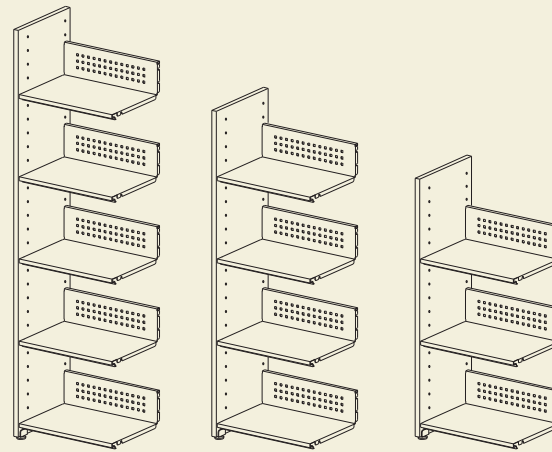

EEC 519
(510x400x1915)

EEC 516
(510x400x1655)

EEC 512
(510x400x1207)

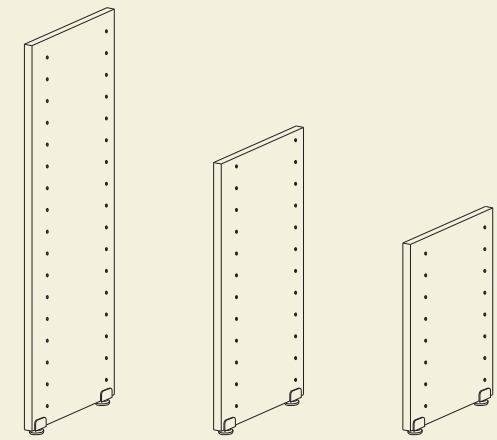

EEW 19
(400x1900x25)

EEW 16
(400x1640x25)

EEW 12
(400x1192x25)

OFFICE

Spider Line



The thing that distinguishes this line from mohm the usage of aluminum and wood, the main reason behind the collection's name is the aluminum spider-like legs. The Standard desk from the spider collection is an ideal choice for a company's manager with its large surface and four drawers arranged from smaller to bigger sizes for a more practical usage. The thing that distinguishes the Spider collection workstation from any other one of mohm's collection is the aperture aluminum partitions, which gives the client the freedom to add hanging shelves or other accessories to free-up the valuable desk space. The Filing Cabinet is a perfect choice for any office as it is a three-in-one piece for multi uses (shelf, drawer and cabinet). The Curvy Reception Counter is the most innovative piece of the Spider collection, its dazzling luxurious front hides the practical side of the counter with two internal work tops standing on elegant slim aluminum legs. The spider collection never ceases to puzzle the client with its variety of furniture pieces; the Puzzle meeting table is one of mohm's latest designs with its trendy practical puzzle pieces design.

OFFICE Partition Line

The Partition Line from mohm depicts the ultimate freedom of designs for the clients. It gives flexibility to adjust the partition in accordance to one's own requirements and free space. The panels and the hanging systems are modular, non-progressive and simple to reconfigure while setting new standards for visual appeal. The system fully integrates with open plan furniture. The partition system provides an array of architectural features and design possibilities required for the private office. Steel work surface supports have no load restrictions under normal use. A variety of cladding materials are available in multiple colors for laminates, textiles, glass & embossed metal that is considered one of our special features.





PA Type

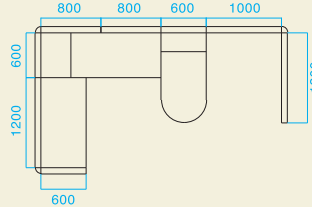
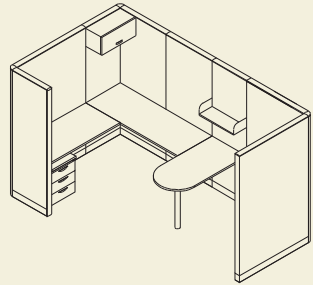

Partition	3 MKPO	0618
	2 MKPO	0818
	1 MKPO	1018
	2 MKPO	1218
Partition L-Post	3 MKPBLP	18
End Bar	2 MKPBE	18
Hanging Desktop	1 MKPSD	160
	1 MKPSD	120
	1 MKCN	612
Hanging Shelf	1 MKPSH	060
Hanging Storage	1 MKPST	060
Drawer	1 MKDW	303

PB Type

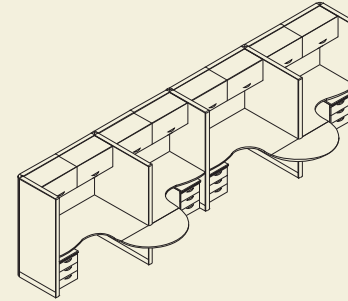

Partition	11 MKPO	0818
	2 MKPO	1218
Partition L-Post	2 MKPBLP	18
T-Post	3 MKPBTP	18
End Bar	5 MKPBE	18
Hanging Desktop	4 PHD	161208 (R/L)
	2 MKCN	120
Hanging Storage	8 MKPST	080
Drawer	4 MKDW	303

PC Type

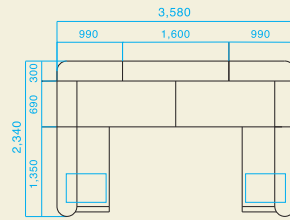
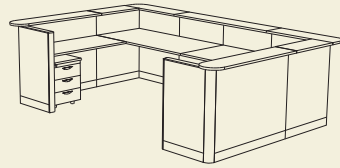

Partition	2 MKPO	0610
	6 MKPO	0810
	2 MKPO	1210
Partition L-Post	4 MKPBLP	10
End Bar	2 MKPBE	10
Hanging Counter	7	
Hanging Desktop	2 MKPD	160
	2 MKPSD	120
Drawer	2 MKDW	303

PD Type

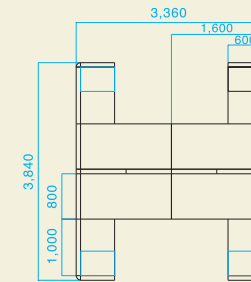
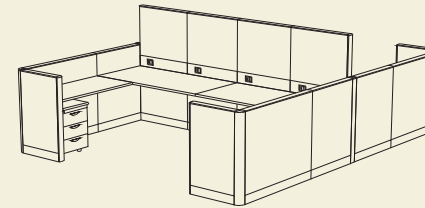

Tile Panel	8 MKPB	0810
	4 MKPB	1210
	4 MKPB	1212
Middle Duct	8 MKPBM	12
T-Post	4 MKPBTP	10
	1 MKPBTP	1
End-Bar	8 MKPBTE	10
	5 Non-Standard	
Desktop	8 MKPD	120
Connector	4 MKCN	112
Drawer	8 MKDW	202
Barcket	14 MKPB	001
	4 Counter	
	8 Bracket	
Chair	4 Swivelling	

PE Type

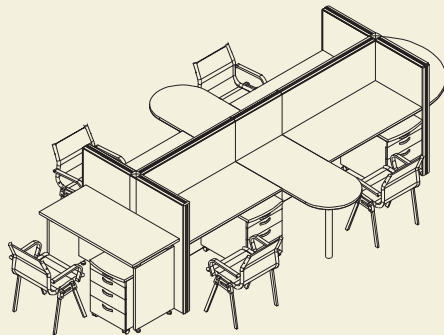

Partition	5 MKPO	0612
	2 MKPO	1212
Partition T-Post	2 MKPBTP	12
End Bar	4 MKPBE	12
Desk	1 MKSD	120
Hanging Desktop	4 MKPSD	160
	2 MKCN	612
	1 MKCN	120
Drawer	5 MKDW	303

PF Type

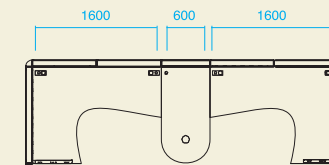
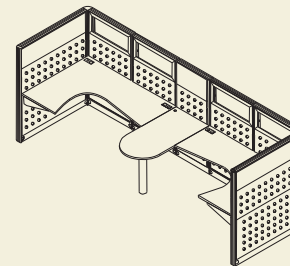

Tile Panel	1 MKPF	0615
	4 MKPF	0815
	2 MKPF	1215
Middle Duct	4 MKPBM	8
L-Post	2 MKPBLP	12
End-Bar	2 MKPBTE	12
Desktop	2 MKPD	1612
Connector	1 MKCN	112

Workstation A

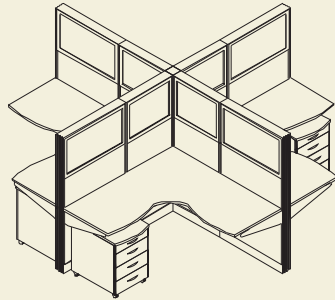

Partition	4 MKPOG	0818
	4 MKPOG	0618
Partition X-Post	1 MKPXP	18
End Bar	4 MKPBE	18
Hanging Desktop	4 PHD	141408 (R/L)
Drawer	4 MKDW	303

Workstation B

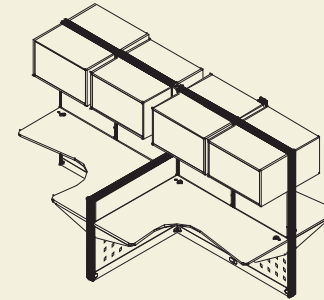

Partition	4 MKPO	0818
	2 MKPO	1210
Partition X-Post	1 MKPXP	18
End Bar	2 MKPBE	18
	2 MKPBE	10
	2 MKPBE	08
Hanging Desktop	4 PHD	161208 (R/L)
Hanging Storage	8 MKPST	080

One Panel System

Fabric & Wood Panel

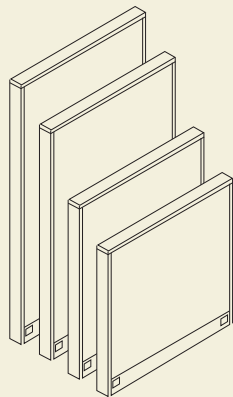

MKPO 0610	(600x1000x80)
MKPO 0810	(800x1000x80)
MKPO 1010	(1000x1000x80)
MKPO 1210	(1200x1000x80)

MKPO 0612	(600x1200x80)
MKPO 0812	(800x1200x80)
MKPO 1012	(1000x1200x80)
MKPO 1212	(1200x1200x80)

MKPO 0615	(600x1500x80)
MKPO 0815	(800x1500x80)
MKPO 1015	(1000x1500x80)
MKPO 1215	(1200x1500x80)

MKPO 0618	(600x1800x80)
MKPO 0818	(800x1800x80)
MKPO 1018	(1000x1800x80)
MKPO 1218	(1200x1800x80)

Glass Window

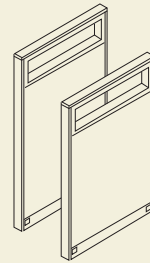

MKPOG 0603	(600x300x80)
MKPOG 0803	(800x300x80)
MKPOG 1003	(1000x300x80)
MKPOG 1203	(1200x300x80)

MKPOG 0606	(600x600x80)
MKPOG 0806	(800x600x80)
MKPOG 1006	(1000x600x80)
MKPOG 1206	(1200x600x80)

T-Post



MKPOTP 10	(H:1000)
MKPOTP 12	(H:1200)
MKPOTP 15	(H:1500)
MKPOTP 18	(H:1800)

X-Post



MKPOXP 10	(H:1000)
MKPOXP 12	(H:1200)
MKPOXP 15	(H:1500)
MKPOXP 18	(H:1800)

L-Post

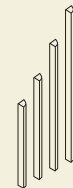

MKPOLP 10	(H:1000)
MKPOLP 12	(H:1200)
MKPOLP 15	(H:1500)
MKPOLP 18	(H:1800)

End Bar



MKPOE 10	(H:1000)
MKPOE 12	(H:1200)
MKPOE 15	(H:1500)
MKPOE 18	(H:1800)

Tile Panel System

Frame



PF 0610 (600x1000x80)
 PF 0810 (800x1000x80)
 PF 1010 (1000x1000x80)
 PF 1210 (1200x1000x80)



PF 0612 (600x1200x80)
 PF 0812 (800x1200x80)
 PF 1012 (1000x1200x80)
 PF 1212 (1200x1200x80)

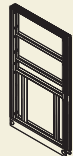

PF 0615 (600x1500x80)
 PF 0815 (800x1500x80)
 PF 1015 (1000x1500x80)
 PF 1215 (1200x1500x80)

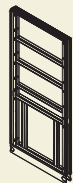

PF 0618 (600x1800x80)
 PF 0818 (800x1800x80)
 PF 1018 (1000x1800x80)
 PF 1218 (1200x1800x80)

Panels

Steel Emboss (thk= 0.8 mm)

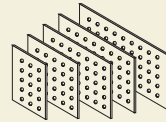

PP 0663SE
 PP 0863SE
 PP 1063SE
 PP 1263SE

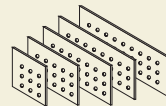

PP 0644SE
 PP 0844SE
 PP 1044SE
 PP 1244SE

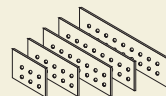

PP 0630SE
 PP 0830SE
 PP 1030SE
 PP 1230SE

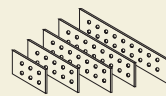

PP 0625SE
 PP 0825SE
 PP 1025SE
 PP 1225SE

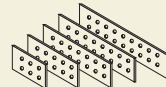

PP 0610SE
 PP 0810SE
 PP 1010SE
 PP 1210SE

Wood (thk= 18 mm)

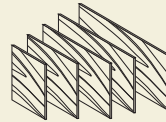

PP 0663W
 PP 0863W
 PP 1063W
 PP 1263W

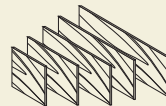

PP 0644W
 PP 0844W
 PP 1044W
 PP 1244W



PP 0630W
 PP 0830W
 PP 1030W
 PP 1230W

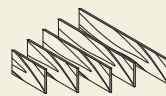

PP 0625W
 PP 0825W
 PP 1025W
 PP 1225W



PP 0610W
 PP 0810W
 PP 1010W
 PP 1210W

Fabric (thk= 20 mm)

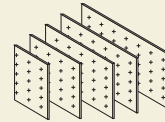

PP 0663F (600x630)
 PP 0863F (800x630)
 PP 1063F (1000x630)
 PP 1263F (1200x630)

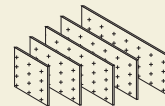

PP 0644F (600x440)
 PP 0844F (800x440)
 PP 1044F (1000x440)
 PP 1244F (1200x440)

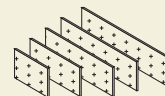

PP 0630F (600x300)
 PP 0830F (800x300)
 PP 1030F (1000x300)
 PP 1230F (1200x300)

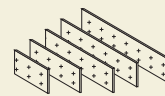

PP 0625F (600x250)
 PP 0825F (800x250)
 PP 1025F (1000x250)
 PP 1225F (1200x250)

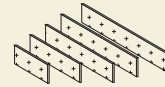

PP 0610F (600x100)
 PP 0810F (800x100)
 PP 1010F (1000x100)
 PP 1210F (1200x100)

Glass (thk= 10 mm)

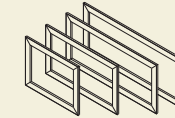

PG 0644G (600x440)
 PG 0844G (800x440)
 PG 1044G (1000x440)
 PG 1244G (1200x440)

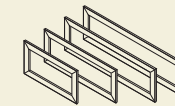

PG 0630G (600x300)
 PG 0830G (800x300)
 PG 1030G (1000x300)
 PG 1230G (1200x300)

Middle Duct

TD= One Side Duct
 DD= Double Side Duct
 TE= One Side Electric Duct
 EE= Double Side Electric Duct



PMD 060
 PMD 080
 PMD 100
 PMD 120



PMDE 060
 PMDE 080
 PMDE 100
 PMDE 120

Hanging Desktop

Desktop

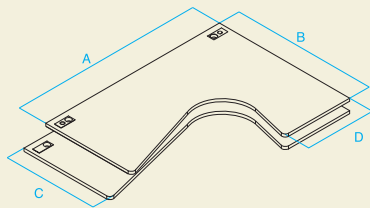
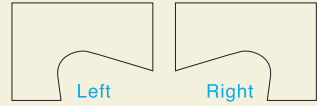

	A	B	C	D	H
PHD 141206	(R/L)	(1400x1200x600X600x25)			
PHD 161208	(R/L)	(1600x1200x800X600x25)			
PHD 161206	(R/L)	(1600x1200x600X600x25)			
PHD 181208	(R/L)	(1800x1200x800X600x25)			
PHD 181206	(R/L)	(1800x1200x600X600x25)			

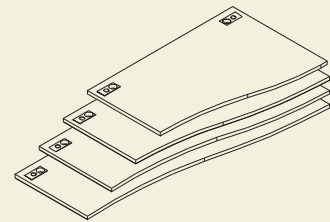

PHD 120 C	(1200x800x600X25)
PHD 140 C	(1400x800x600X25)
PHD 160 C	(1600x800x600X25)
PHD 180 C	(1800x800x600X25)

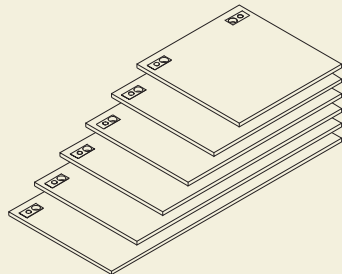

MKPD 080	(800x800X25)
MKPD 100	(1000x800X25)
MKPD 120	(1200x800X25)
MKPD 140	(1400x800X25)
MKPD 160	(1600x800X25)
MKPD 180	(1800x800X25)

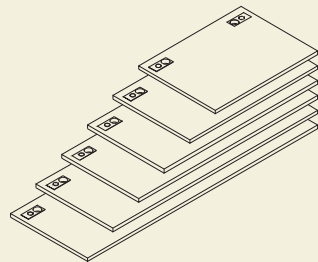

MKPSD 080	(800x600X25)
MKPSD 100	(1000x600X25)
MKPSD 120	(1200x600X25)
MKPSD 140	(1400x600X25)

Accessories

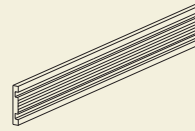

Accessory Bar	
MKPAB 060	(W:600)
MKPAB 080	(W:800)
MKPAB 100	(W:1000)
MKPAB 120	(W:1200)

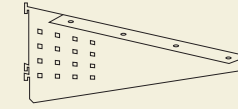

MKPB 001 (R/L) Bracket

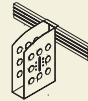

MKPA 001 (Book Holder)



MKPA 002 (Paper Holder)



MKPA 003 (Pencil Tray)



MKPA 004 (Telephone Holder)



MKPA 005 (Office Tools Tray)

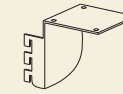

MKPSB 001(R/L) Bracket

Hanging Shelf

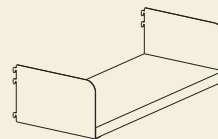

MKPSH 060	(W:600)
MKPSH 080	(W:800)
MKPSH 100	(W:1000)
MKPSH 120	(W:1200)

Hanging Box

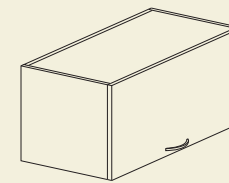

MKPST 060	(W:600)
MKPST 080	(W:800)
MKPST 100	(W:1000)

BASIC LINE



Metal Desks

D23 (100x60x75cm)

D24 (120x75x75cm)

D25 (150x75x75cm)

D25A (150x75x75cm)

D26 (180x90x75cm)

D35 (120x75x75cm)

D36 (150x75x75cm)

D37 (180x90x75cm)



File Cabinet

- C17** - Filing cabinet 4 drawers
(46x64x132cm)
C17A - Filing cabinet 3 drawers
(46x64x101cm)
C17B - Filing cabinet 2 drawers
(46x64x70.8cm)



Anti Fire Filing Cabinets

- CFB4** - Anti fire Cabinets - 4 drawers
(52x75x150cm)
CFB3 - Anti fire Cabinets - 3 drawers
(52x75x116cm)
CFB2 - Anti fire Cabinets - 2 drawers
(52x75x83cm)



Rack Shelf

- C21A** - Includes 5 shelves
(90x40x198cm)
C23A - Includes 5 shelves
(90x40x298cm)
C37A - Includes 7 shelves
(90x40x298cm)



Sliding Cabinet

- C24** (130x40x95cm)



Cabinets

- C10** (90x41x182cm)
C12 (90x51x182cm)



Cupboard

- C12** - for home use
 a section for shelves
 a section for hangers
 (90 x 50 x 180 cm)



Standard Lockers

- C13** 4 doors (40x50x180cm)
C13A 4 doors (30x40x180cm)
C14 2 doors (40x50x180cm)
C14/15 3 doors (40x50x180cm)
C15 1 doors (40x50x180cm)



Premium Lockers

- PM15** 1 door (30x50x180cm)
PM15A 1 door (40x50x180cm)
PM14 2 doors (30x50x180cm)
PM14A 2 doors (40x50x180cm)
PM14/15 3 doors (30x50x180cm)
PM14/15A 3 doors (40x50x180cm)
PM13 4 doors (30x50x180cm)
PM13A 4 doors (40x50x180cm)



Metal Bed

- B101** (90x214x89cm)
B102 (100x214x89cm)



Metal Bed

- B104** (90x214x161cm)



With Wooden Support

- B101W** (90x214x89cm)
B102W (100x214x89cm)



With Wooden Support

- B104W** (90x214x161cm)

OFFICE

Dynamic Line

According to modern life mohm created a newly style of workstations, Being aware that a desk for any employee is his sincere companion, mohm designs a work station with new modern colors, made work a daily pleasure, mohm has excelled in creating a wire caps to solve cabling problems, Top of dynamic desk is made of MDF 25mm, covered with laminate, PVC edges, For more privacy disks is separated by upholstered purple color partitions ,Disk Legs made of metal tubes 70*40 mm characterized by its simple designs, which is going well with desk in order to create a pleasant working area, all metal parts coated with electrostatic powder.



Workstations

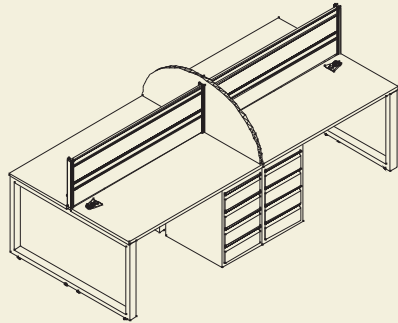

Desk	4 DYD	614
Screen	2 DYAS	140
	2 DYWS	122
Drawers	4 DYW	400M

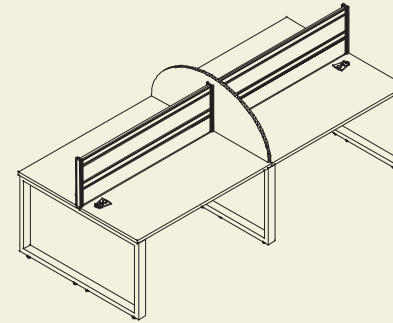

Desk	4 DYD	614
Screen	2 DYAS	140
	2 DYWS	122

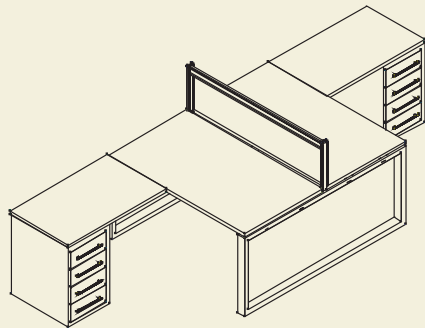

Desk	2 DY	816
Side Desk	2 DYSD	100
Screen	1 DYAS	160

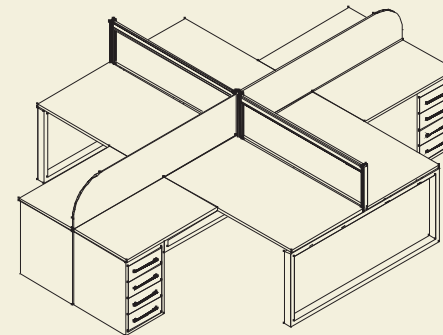

Desk	4 DY	816
Side Desk	4 DYSD	100
Screen	2 DYAS	160
	2 DYFS	180

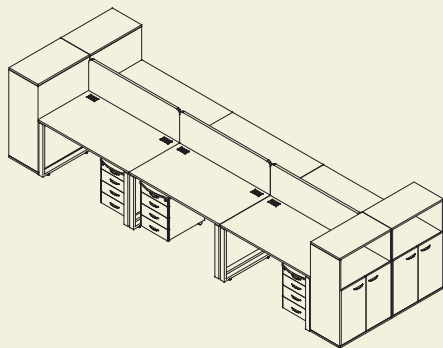

Desk	6 DY	612
Drawer	6 DYW	400W
Screen	3 DYWS	120
Cabinet	4 MKC	480

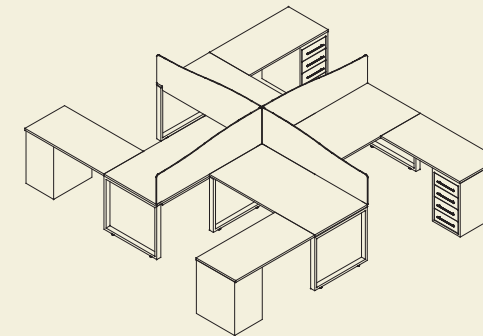

Desk	4 DY	816
Side Desk	4 DYSD	100
Screen	4 DYWS	160

Manager Desk

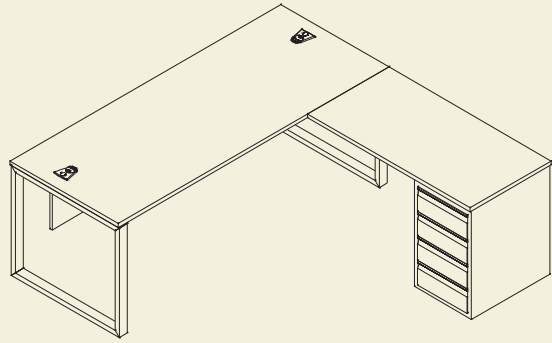

Desk DY 820
 Side Desk DYS 100
 Drawers DYW 300W

Desks

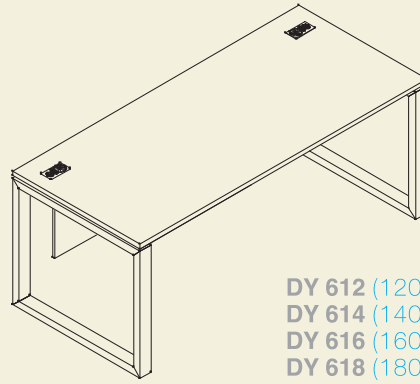

DY 612 (1200x600x750)
 DY 614 (1400x600x750)
 DY 616 (1600x600x750)
 DY 618 (1800x600x750)

DY 812 (1200x800x750)
 DY 814 (1400x800x750)
 DY 816 (1600x800x750)
 DY 818 (1800x800x750)
 DY 820 (2000x800x750)

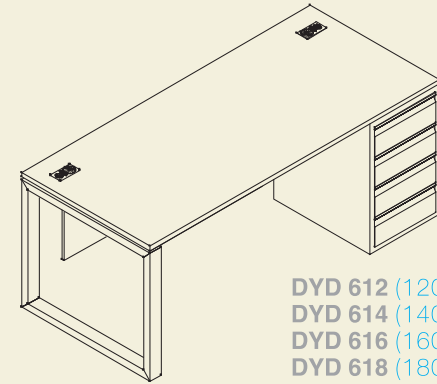

DYD 612 (1200x600x750)
 DYD 614 (1400x600x750)
 DYD 616 (1600x600x750)
 DYD 618 (1800x600x750)

DYD 812 (1200x800x750)
 DYD 814 (1400x800x750)
 DYD 816 (1600x800x750)
 DYD 818 (1800x800x750)
 DYD 820 (2000x800x750)

Side Desk

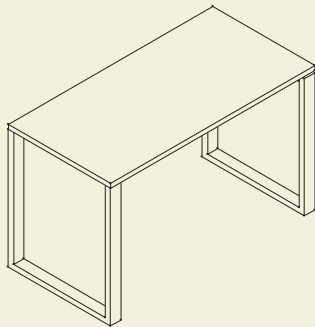

DYS 080 (800x600x750)
 DYS 100 (1000x600x750)

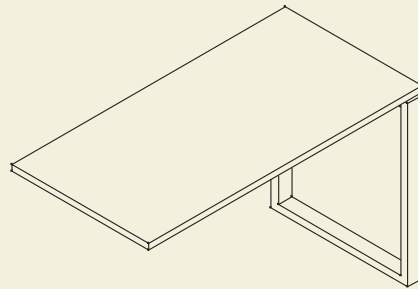

DYSE 080 (800x600x750)
 DYSE 100 (1000x600x750)

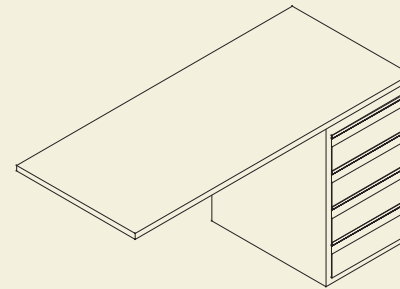

DYSD 100 (1000x600x750)

Drawers

W (Wooden Face) - M (Metal Face) - U (Upholstry Top)

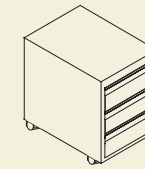

DYW 300M (420x580x615)
 DYW 300U (420x580x458)

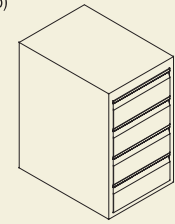

DYW 400M (420x580x720)
 DYW 400U (420x580x458)



DYW 300W (420x580x615)

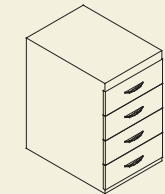

DYW 400W (420x580x720)

Meeting Tables



DYM180 | 1800x1200x750
 DYM210 | 2100x1200x750
 DYM240 | 2400x1200x750

Tea Tables



DYT90 | 500x500x400



DYT50 | 500x500x400

Metal Dynamic Cabinets



Screens



Fabric Screen

DYFS 120 | 1200x450x40
 DYFS 140 | 1400x450x40
 DYFS 160 | 1600x450x40
 DYFS 180 | 1800x450x40
 DYFS 200 | 2000x450x40

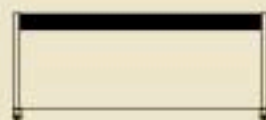

Aluminum Screen (1)

DYAS 1 120 | 1200x450x17
 DYAS 1 140 | 1400x450x17
 DYAS 1 160 | 1600x450x17
 DYAS 1 180 | 1800x450x17
 DYAS 1 200 | 2000x450x17



Aluminum Screen (2)

DYAS 2 120 | 1200x450x17
 DYAS 2 140 | 1400x450x17
 DYAS 2 160 | 1600x450x17
 DYAS 2 180 | 1800x450x17
 DYAS 2 200 | 2000x450x17



Tempered Glass Screen

DYGS 120 | 1220x450x10
 DYGS 140 | 1420x450x10
 DYGS 160 | 1620x450x10
 DYGS 180 | 1820x450x10



Tempered Glass Separator

DYGP 122 | 1220x480x10
 DYGP 124 | 1240x480x10
 DYGP 162 | 1620x480x10
 DYGP 164 | 1640x480x10



Wood Separator

DYWP 122 | 1220x480x18
 DYWP 124 | 1240x480x18
 DYWP 162 | 1620x480x18
 DYWP 164 | 1640x480x18

OFFICE

Infinity Pro

Finally using simple elements and colors to individualize corporate concepts, Infinity is a new line that raises brows and makes room for reflection and meditation. Infinity is a blend of mysticism and practicality.

The entangled steel background takes a new route in design and manufacturing that rebel against monotonous classicism. The tables allows for myriad sets of arrangement. A grey, white and black harmony invites an assortment of matching colors and accessories to lighten up the business mood. The cabinets are made to accentuate the infinite flexibility of the line.



Workstations

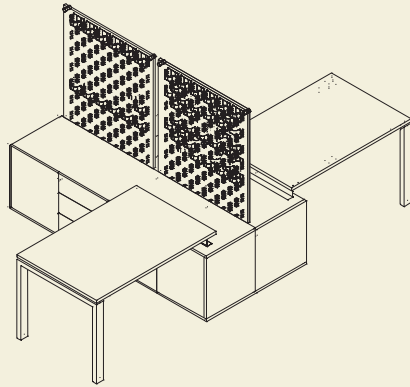

Desk 2 IN 1012
Credenza 2 INCN 200
Screen 4 INS 95

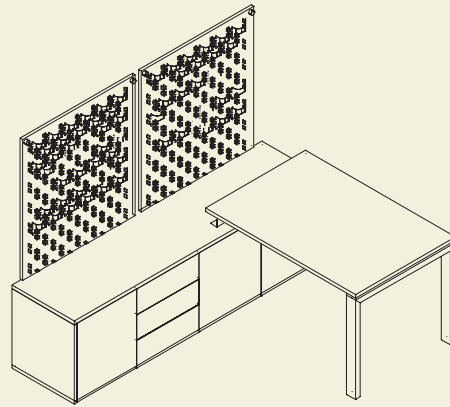

Desk 1 IN 812
Credenza 1 INCN 200
Screen 2 INS 130

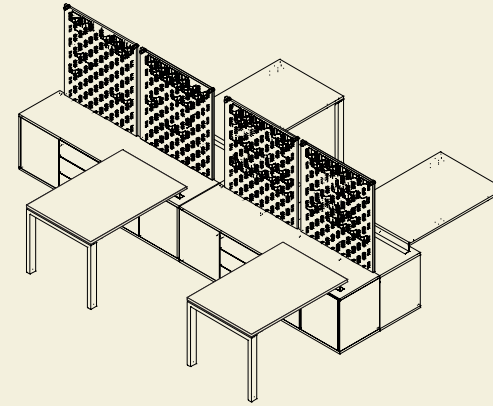

Desk 4 IN 1012
Credenza 4 INCN 200
Screen 8 INS 95

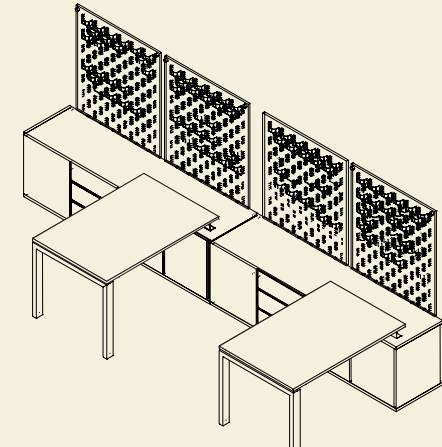

Desk 1 IN 1010
Desk 1 IN 610
Credenza 2 INCN 200
Screen 4 INS 130

Desks

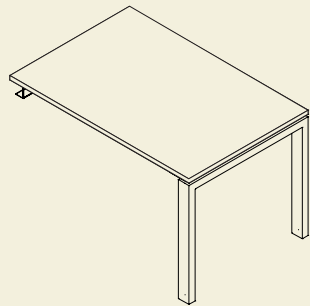

IN 810 (1000x800x750) IN 1010 (1000x1000x750)
IN 812 (1200x800x750) IN 1012 (1200x1000x750)
IN 814 (1400x800x750) IN 1014 (1400x1000x750)
IN 816 (1600x800x750) IN 1016 (1600x1000x750)
IN 818 (1800x800x750) IN 1018 (1800x1000x750)
IN 820 (2000x800x750) IN 1020 (2000x1000x750)

IN 610 (1000x600x750)
IN 612 (1200x600x750)
IN 614 (1400x600x750)
IN 616 (1600x600x750)
IN 618 (1800x600x750)
IN 620 (2000x600x750)

Credenza

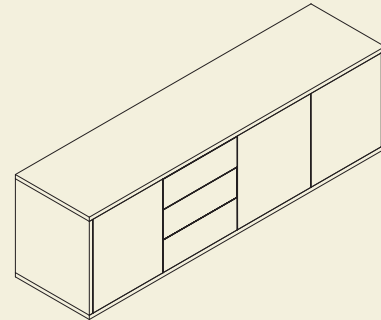

INCN 200
(2000x500x625)

Screens

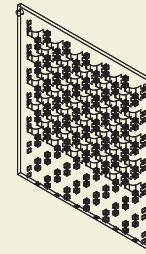

INS 95
(950x900x45)
INS 130
(950x900x45)

Accessories



Pencil Cup
INAC 6
(150x150x200)

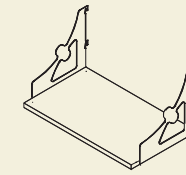

Shelf
INAC 29
(290x500x200)

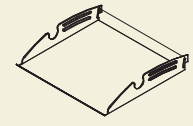

Shelf
INAC 24
(240x240x50)

EXECUTIVE NOVALINEA



Mohm specialized by its nice and luxurious office which gives a very relaxing and enjoyable atmosphere to work in day in and day out. There is nothing better than a tall and deep desk chair and a wide desk to make for a comfortable but also NOVALINEA office look and feel. Although many people don't think often about their office furniture, for those people who work at home, the office is the most important room in the house. Take advantage of this room and create a room of success and luxury with MOHM'S office pieces.

NOVALINEA Top, Side, Front panel & Legs is made of MDF, covered with laminated natural oak veneer, the NOVALINEA structure is made of beech, Painted with polyurethane painting.

Desks

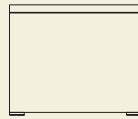
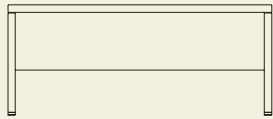
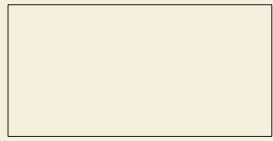

NOD 180 (1800x900x750mm)
NOD 210 (2100x900x750mm)
NOD 240 (2400x900x750mm)

Side Desks

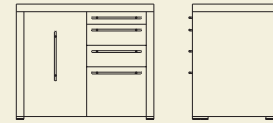
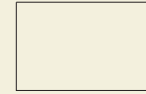
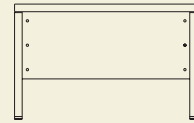
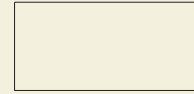

NOSD 120
 (900x600x650)

NOSD 090
 (900x600x655)

Credenza

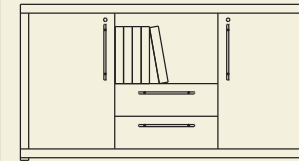

NODD 0917
 (1700x900x400mm)

Meeting Tables

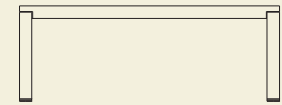

NOMT 180 (1800x900x750mm)
NOMT 210 (2100x900x750mm)
NOMT 240 (2400x900x750mm)

With lamp
NOMT 180L (1800x900x750mm)
NOMT 210L (2100x900x750mm)
NOMT 240L (2400x900x750mm)

Cabinets

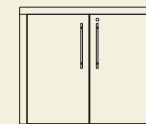
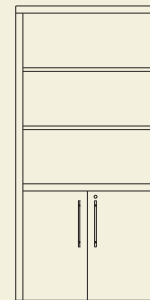
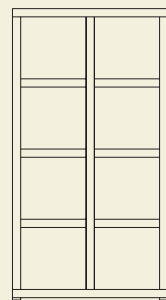
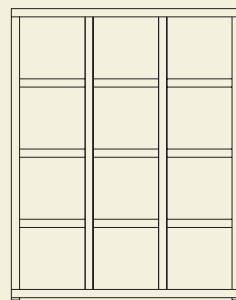
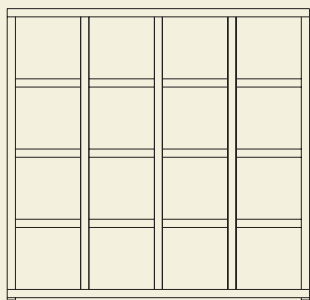

NOC 180
 (1775x2100x400mm)

NOC 135
 (1340x1775x400mm)

NOC 090
 (900x1775x400mm)

NOCD 2105
 (500x2100x400mm)

NOCD 2110
 (1000x2100x400mm)

NODD 0910
 (902x1000x400mm)

Tea Tables

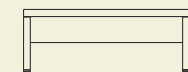
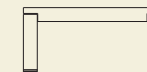
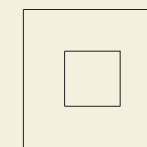

NOVTA 100
 (1000x1000x450mm)

NOVTA 050
 (500x500x442mm)

NOVTA 120
 (1200x500x442mm)

NOVTA 105
 (1000x500x442mm)

EXECUTIVE ITALIAN

What is so different about MOHM office furniture compared to other types of it? One's work place, the area where people unfortunately (or is it fortunately) spend the most of their time is equipped with such type of furniture. This is why one should equip his or her office in such a way that one feels comfortable in it but also in a way that the interior would stimulate one's working performances.

When choosing items of interior for your working place, you should accord to the rhythm of your working day and the position you're in. Boss' armchair is the indicator of one's status and also an indicator of how successful the whole organization is. Therefore a rich and prosperous decoration would indicate one's high position whereas a plain office table would reveal a rather low status of its owner.



Desks

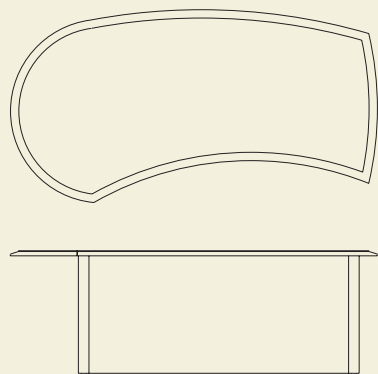

ITD 240 (2400x1160x750mm)
ITD 220 (2200x1000x750mm)
ITD 180 (2200x1150x750mm)

Side Desks

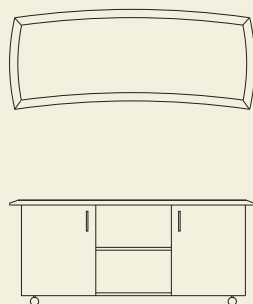

ITD180 (1490x610x640)

Tea Table

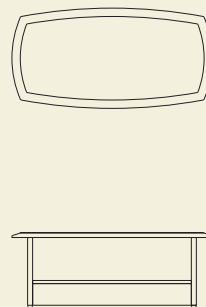

ITTA 12/6 (1215x610x450)
ITTA 50 (500x500x450mm)

Conference Units

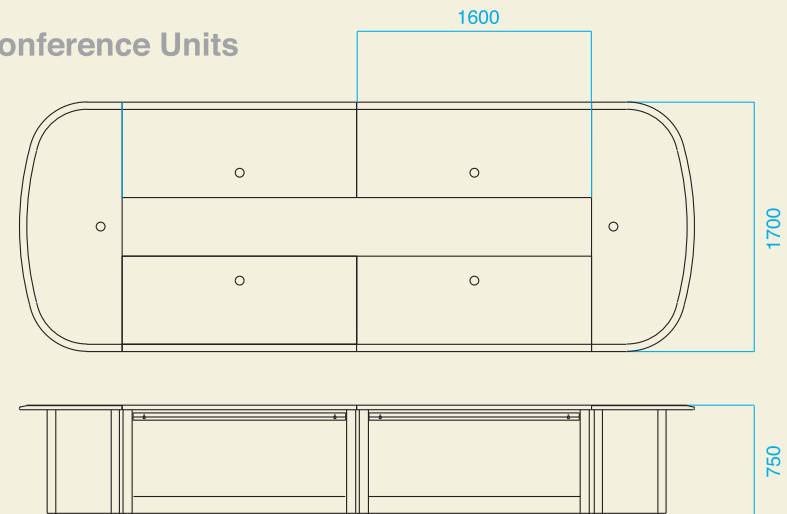

ITCO 160 (1600x650x750mm)
ITCO 170 (1700x650x750mm)

Cabinet

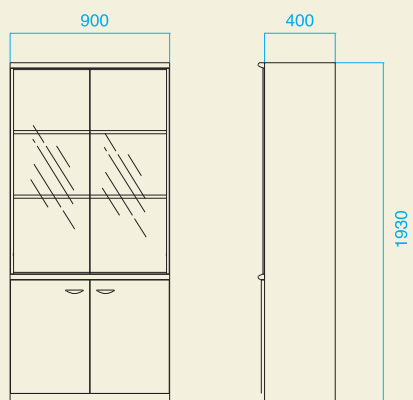

ITC 190 (900x437x1930)

Credanza

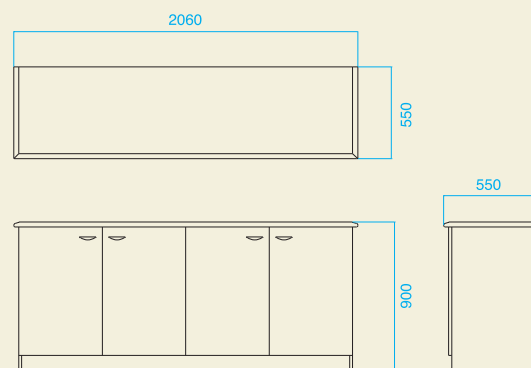

ITCR 200 (2020x550x900)

Drawers

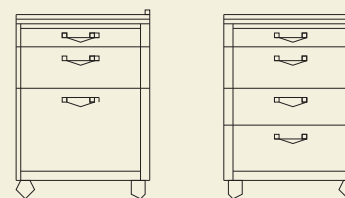

ITW 300 (455x528x650mm)
ITW 400 (455x528x650mm)

Meeting Table

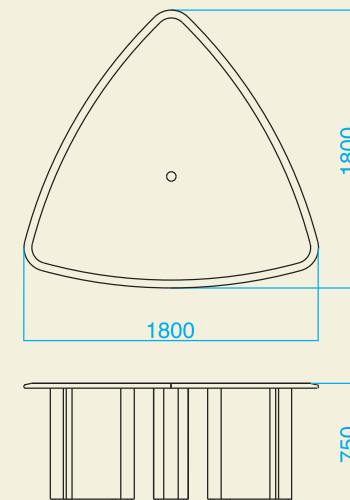

ITCO 180 (1800x1800x750mm)

OFFICE Fly System

MOM's avant-guardist FLY line goes with in harmony with the vivid retro 1960s and 1970s designs of interior design that came back with the new millennium. We are confident that the overwhelming youthful spirit of thriving executives goes perfectly with designs that hover around office spaces with creativity and originality. Smoothly, MOHM's FLY line could draw us into the revolutionary spirit of the 1960s, making the best of its practicality without giving up an inch of its texture, perspective and volume. The top boasts of its light colour to bring a striking contrast with the dark (mostly black) rich leather armchairs together with the steel table legs. The centre of the table is in glass to add light and glow to the surface.

The bookcase is a gripping model that takes a new route in design and manufacture. It builds on the unexpected and seemingly unfinished lines of its center part that tops a solid cabin to add to its contrasting concepts. With FLY, MOHM takes off a rugged path to bring a twin professional and artistic look to its home and office spaces.



Desks

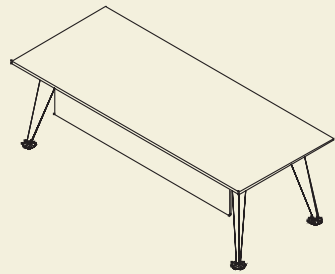

FD 240 (2400x1000x740)
 FD 210 (2100x1000x740)
 FD 180 (1800x1000x740)

Side Desk

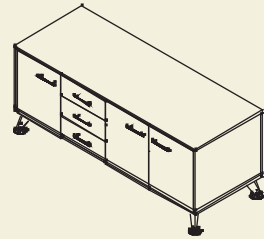

FS 160 (1600x600x690)

Frame

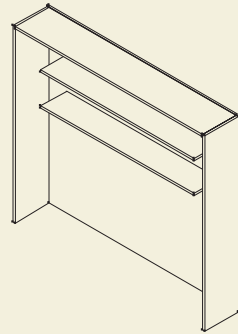

FF 240 (2400x2200x400)

Credenza

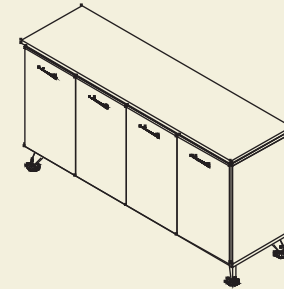

FC 200 (2000x450x850)

Drawer

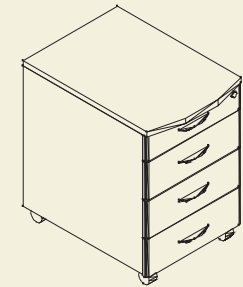

FD 300 (430x570x640)

Meeting Table

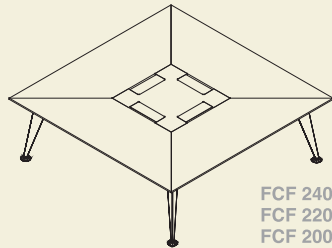

FCF 240S (2400x2400x740)
 FCF 220S (2200x2200x740)
 FCF 200S (2000x2000x740)

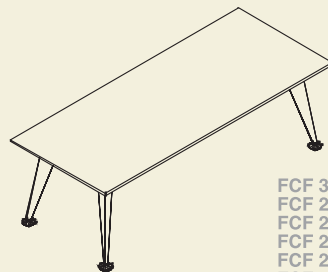

FCF 300R (3000x1200x740)
 FCF 280R (2800x1200x740)
 FCF 260R (2600x1200x740)
 FCF 240R (2400x1200x740)
 FCF 220R (2200x1200x740)
 FCF 180R (2000x1200x740)

Cabinets

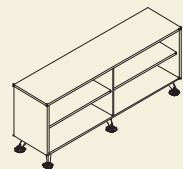

FLC 85 (2000x500x850)

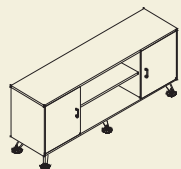

FLC2D 85 (2000x500x850)

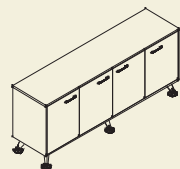

FLC4D 85 (2000x500x850)

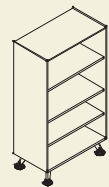

FLC 160 (900x500x1600)



FLC2BD 160 (900x500x1600)

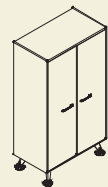

FLC2D 160 (900x500x1600)

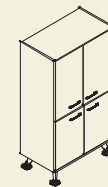

FLC4D 160 (900x500x1600)

Manager Desk

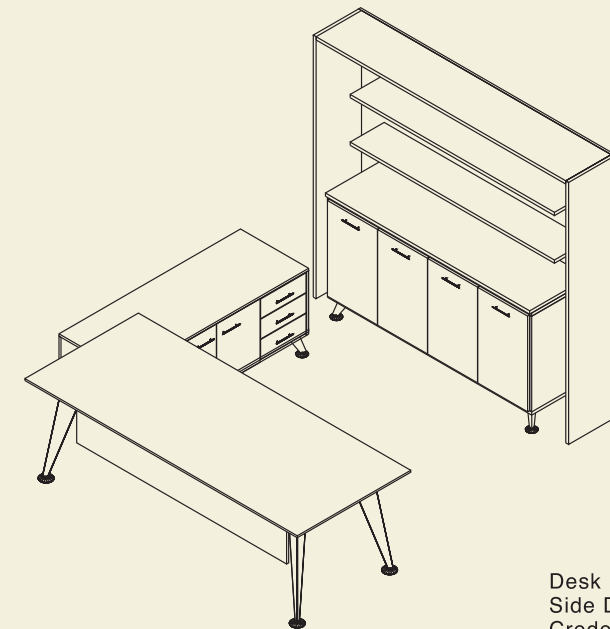

Desk FD 210
 Side Desk FS 160
 Credenza FC 200
 Frame FF 240

CHAIR

Chesterfield



CHN 564



CHN 562

Series of seats aimed at prestigious management environments, Covered in real leather , enhanced by the particular quilted working that characterizes the lower back rest , mohm created line of seats for chairmen or management, high quality standards made in real natural leather (material optional).these characteristics merge elegant forms and accurate finishes.

Mesh Chair



CHH/N 103
high back chair



CHH/N 102
low back chair



CHH/N 101
visitor chair

Florida



CH 888
high back chair



CH 889
low back chair



CH 890
visitor chair

Premium



CHP 24
high back chair



CHP 25
low back chair



CHP 26
visitor chair

Sphere



CHBX 172
low back chair



CHBX 170 V
visitor chair

Dual



CH 210
Back can be covered in leather

Clerk



CH 200
low back chair



CHV 200
visitor chair

Concord



CH 333
high back chair



CH 334 (wide)
low back chair



CH 335 (regular)
low back chair



CH 336
visitor chair



CH 337
visitor chair

Classic



CH 400
high back chair



CH 401
low back chair



CH 402
visitor chair

Luxury



CH 501
high back chair

Smart



CHSMC
meeting chair

Ergonomic



CH 930
high back chair



CH 931
low back chair



CH 932
visitor chair

Extreme



CH 630
high back chair



CH 631
low back chair



CH 632
visitor chair

Carina Fabric



CHC 102-102A-102L
Carina Fabric
A: Arms L: Lecture



CHC 202
Carina lobby seat fabric



CHC 302
Carina lobby seat fabric

Carina Plastic



CHC 101-101A-101L
Carina Plastic
A: Arms L: Lecture



CHC 201
Carina lobby seat plastic



CHC 301
Carina lobby seat plastic

Theater Chair



CHT 101

Long Back



CH 700
long back chair

Media



CH 620

Carina on Wheels



CHC VI 104

Lite



CHL 200

Basic line



CH 650



CH 615



CH 600



CH 616 (Chrome)
CH 601 (Paint)



CH 625C (Chrome)
CH 625 (Paint)



Alfa



CH 649



CH 613 (1 Seat)
CH 614 (3 Seats)

D Chair



CH 668

SOFA

Curve Lobby System

- CLSBF 50 (122.5 x 68 x 39 cm) Banquette
- CLSBBF 50 (122.5 x 68 x 67 cm) Banquette High Back
- CLSBSF 70 (122.5 x 68 x 67 cm) Banquette Low Back



In all offices this is an areas important that needs to be furnished. Areas set aside for those who wait are the 'visiting card ' that shows the image of the company also shows hospitality and warmth, mohm created series of important and representational upholstered items . these comprise 2-seater and 3-seater sofas, with a variety of materials (natural & artificial) and colors (color optional).

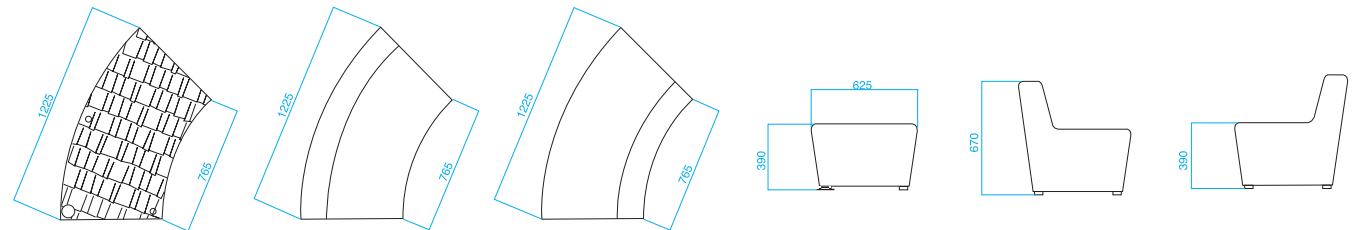

Carre



CHN 190 (100 x 95 x 74 cm) (1 seat)
CHN 191 (170 x 95 x 74 cm) (1 seat)
CHN 192 (230 x 95 x 74 cm) (1 seat)

Chesterfield



CHS 121 (118 x 90 x 75 cm) (1 seat)
CHS 122 (180 x 90 x 75 cm) (2 seat)
CHS 123 (225 x 90 x 75 cm) (3 seat)

Sienna



CHSN 181 (95 x 85 x 75 cm) (1 seat)
CHSN 182 (165 x 85 x 75 cm) (2 seat)
CHSN 183 (213 x 85 x 75 cm) (3 seat)

Elegant



CH 446 (64 x 65 x 83 cm) (1 seat)
CH 447 (114 x 65 x 83 cm) (2 seat)
CH 448 (164 x 65 x 83 cm) (3 seat)

Relax



CH 342
(66 x 57 x 84 cm)

Chesterfield classic



CHN 558 (118 x 90 x 73 cm) (1 Seat)
CHN 559 (170 x 90 x 73 cm) (2 Seat)
CHN 560 (220 x 90 x 73 cm) (3 Seat)

Alex



CH 341 (114 x 80 x 64 cm) (1 seat)
CH 342 (164 x 80 x 64 cm) (2 seat)
CH 343 (224 x 80 x 64 cm) (2 seat)

Hamburg



CH 106 (90 x 75 x 78 cm) (1 seat)
CH 107 (150 x 75 x 78 cm) (2 seat)

Sylvia



CHS 121 (84 x 73 x 83 cm) (1 seat)
CHS 122 (137 x 73 x 83 cm) (2 seat)
CHS 123 (174 x 73 x 83 cm) (3 seat)

OFFICE COUNTER



Spider



Elegant



Fusion

Since receptions are one of the essential locations in any office, Mohm has created many designs for counters. Our counters can be custom made as per client's requirements. Mohm counters are matching with the products lines such as the elegant counter and the spider counter. Fusion counter is our newest invention with many variations.

Elegant Counter

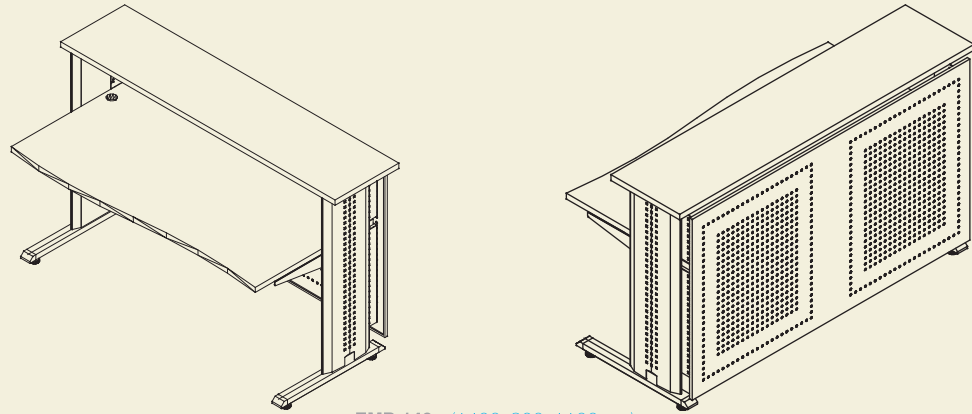

EMD 140 (1400x800x1100mm)
EMD 160 (1600x800x1100mm)
EMD 180 (1800x800x1100mm)

Spider Counter

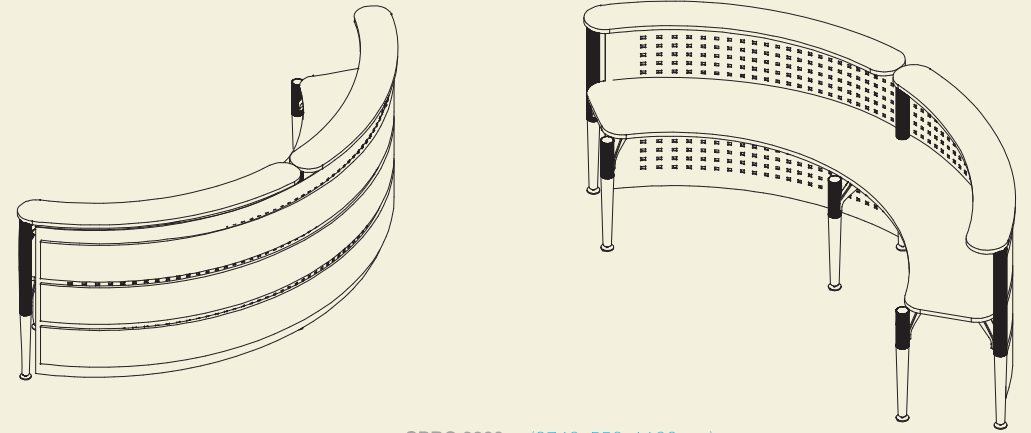

SPRC 2800 (2740x550x1100mm)
SPRC 1400 (1400x550x1100mm)

Fusion Counter

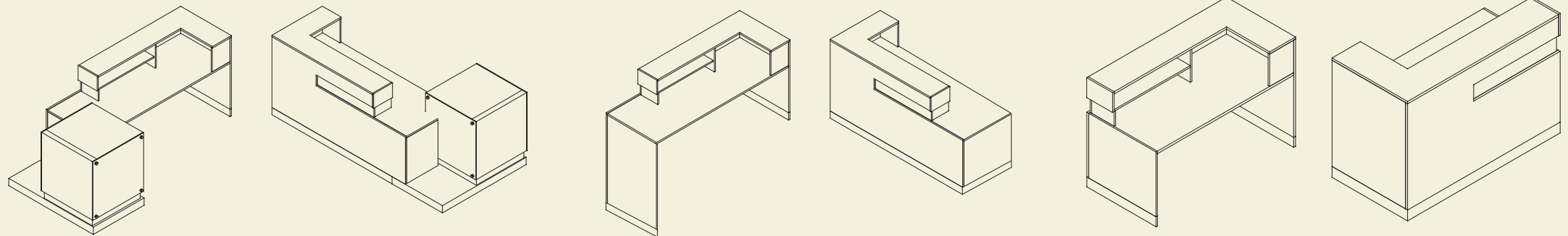

FCF 28B
(2800x1000x1100mm)

FCF 20
(2000x1000x1100mm)

FCF 16
(1600x1000x1100mm)

SCHOOL (EDUCATION)



LECTURE BENCH
LB01
(380x580x740)



Lighted Library
LL 01
(900x400x2000)



Reading Unit
SRU 01
(1000x600x740)



Computer Unit
SCU 01
(800x600x740)

Egypt has the largest overall education system in the Middle East and North Africa(MENA) and it has grown rapidly since the early 1990s. Some schools in Egypt trusted MOHM the innovative furniture company to handle the task of furnishing it, so mohm designed suitable benches with a variety in dimensions to fit all edges (colors optional) and also lab tables.

Student Desks



WL 158
(150x860x750)



SDP 068
(420x360x680)
SDT 077
(510x440x770)
SDS 084
(510x440x840)



SDP1 068
(1050x440x670)
SDT1 077
(1050x440x710)
SDS1 084
(1050x440x750)



SC 440
(400x400x460)

ST 750
(700x500x760)



SSD 790
(700x900x720)

Student Chairs



EB 103P
(510x360x680)
EB 103T
(510x440x770)
EB 103S
(510x440x840)



EBL 103P
(510x360x680)
EBL 103T
(510x440x770)
EBL 103S
(510x440x840)



Carina Lecture
CHC 102L
(500x500x820)



Stadum Chair
STC 2003
(510x550x800)



Garden Bench
GBC 2003
(1800x530x800)

Educational Tables



TT 126
(1200x600x450)



TT 110
(1000x1000x450)



TT 120
(D1200xH450)



PT 880
(800x800x650)



RT 147
(1400x700x750)



RT 117
(1100/680x700x750)



Changing Rooms



Faces Locker
FL 189
(900x440x1800)



Leveled Locker
LL1 160
(600x1000x2000)



Double Bench with HangIng
DBH 129
(1200x900x2000)



Single Bench with HangIng
SBH 124
(1200x450x2000)



Double Bench
DB 129
(1200x900x800)



Single Bench
SB 124
(1200x450x800)



Single Bench
SB 120
(1200x450x450)

Labs



Lab Chair
LCH 350
(D350xH550)



Swivel Lab Chair
LCH 500
(D350xH580)



MWS 150
(1500x600x850)



MTS 150
(1500x600x850)



SWS 150
(1500x600x850)



STS 150
(1500x600x850)

K.G Desks



KGD 167
(650x500x670)
KGD 174
(650x500x740)



KGD 152
(1200x600x520)
KGD 158
(1200x600x580)



KGDT 152
(1200/600x600x520)
KGDT 158
(1200/600x600x580)



TD 160
(1000x600x740)

K.G Cabinets



KGC 900
(900x400x1800)



KGC 1200
(1200x300x1800)



KGCO 1200
(1200x300x1800)

Some of the designs are subject to change without prior notice, please consult with our sales team before making an order

www.multigroup.com